

APPLICATION NOTE

Model 372 AC Resistance Bridge Installation Best Practices for Measurement in a Dilution Refrigerator



As dilution refrigerator (DR) designs enable temperatures that edge ever closer to absolute zero, the ability to accurately measure and report these temperatures becomes increasingly challenging. Typically, an AC bridge is used to excite and read an ultra-low temperature (ULT) RTD using minimal power. However, at the extremes, external noise suppression becomes a critical factor. This document reviews techniques for minimizing the impact of noise on DR temperature measurement accuracy.

To briefly summarize the industry-standard approach for ULT measurement:

- Temperature is inferred from the measured electrical resistance of a temperature sensor such as the **Rox™ RX-102B-RS ultra-low-temperature sensor**.
- A known AC current is applied to the sensor, the resultant voltage across the resistor is measured, and the sensor's resistance is then calculated using Ohm's Law.
- To eliminate DC offsets from multiple sources, AC waveforms (preferably sine wave to minimize higher frequency harmonics) are used. Low frequencies (<20 Hz) minimize error from cable capacitance.
- Currents and voltages are minimized to reduce self-heating of the sensor. However, because of these low signal levels, measurements can be very susceptible to external noise energies.

For greater detail on the general measurement approach summarized above, the [Lake Shore Model 372 product manual](#) is an excellent source of information.

Obvious sources of sensor self-heating

Due to the extreme low temperatures of a dilution refrigerator, thermal connection with the sample stage or experiment can be extremely weak. This makes the sensor vulnerable to external sources that can cause the sensor to become warmer than the surface it is mounted to. The following effects are some of the most obvious sources of unwanted heating, as they come directly from the measurement instrumentation. In most cases, they should be minimized for accurate temperature readings.

Sensor excitation current

Resistance measurement requires that an AC or DC current be passed through a resistor with the resultant voltage measured across the resistor. This energy is dissipated as heat in the resistor during the measurement. To minimize self-heating, the currents and voltages used for cryogenic temperature measurement need to be very low. Using AC excitation allows the use of a lock-in receiver, meaning much smaller signals can be used than a simple DC measurement, which would need to use a signal large enough to be visible above any measurement noise.

As an example of self-heating as a result of drive current, consider the situation of a Model 372 AC bridge measuring a typical RX-102B-RS sensor at 10 mK:

RX-102B-RS at 10 mK

Typical resistance = 9,856 Ω

Typical thermal resistance = 3 × 10¹⁰ K/W

Model 372 reading this sensor at recommended excitation:

Recommended range: 20 kΩ

Recommended drive current: 100 pA

Calculate power dissipated into the sensor

$$\begin{aligned} \text{RMS power} &= I^2 R \\ &= (100 \text{ pA})^2 \times 9,856 \Omega \\ &= 9.856 \times 10^{-17} \text{ W (98.56 aW)} \end{aligned}$$

Self-heating = thermal resistance × power

$$\begin{aligned} &= 3 \times 10^{10} \text{ K/W} \times 9.856 \times 10^{-17} \text{ W} \\ &= 2.96 \mu\text{K (acceptable)} \end{aligned}$$

Model 372 reading this sensor with too much power:

Recommended range: 20 kΩ

Excessive drive current: 10 nA

Calculate power dissipated into the sensor

$$\begin{aligned} \text{RMS power} &= I^2 R \\ &= (10 \text{ nA})^2 \times 9,856 \Omega \\ &= 9.856 \times 10^{-13} \text{ W (985.6 fW)} \end{aligned}$$

Self-heating = thermal resistance × power

$$\begin{aligned} &= 3 \times 10^{10} \text{ K/W} \times 9.856 \times 10^{-13} \text{ W} \\ &= 29.6 \text{ mK (unacceptable)} \end{aligned}$$

DC bias currents

Although an AC bridge is sensitive to only AC signals for its measurement, there are small parasitic currents summed from all internal op-amps that connect to the sensor. While a fully-balanced current source and instrument amplifier help to minimize this, a DC bias offset remains that differs between the positive and negative excitation and voltage leads. In the case of the Lake Shore Model 372 AC resistance bridge, this DC bias is measured during calibration and confirmed to be less than 4 pA, typically closer to 1 pA for both the 3726 scanner and the Model 372 itself.

Using the same scenario as the previous example:

$$\begin{aligned} \text{RMS power} &= I^2 R \\ &= (4 \text{ pA})^2 \times 9,856 \Omega \\ &= 1.58 \times 10^{-19} \text{ W (0.158 aW)} \end{aligned}$$

Self-heating = thermal resistance × power

$$\begin{aligned} &= 3 \times 10^{10} \text{ K/W} \times 1.58 \times 10^{-19} \text{ W} \\ &= 4.74 \text{ nK (acceptable)} \end{aligned}$$

By contrast, an AC bridge with 1 nA of DC bias would result in around 0.3 mK of self-heating.

Less obvious sources

Electromagnetic radiation

Blackbody radiation from surfaces that are in direct sight of the sensor can cause energy to be transferred into the sensor, resulting in heating. Ensure that the sensor is enclosed in a shielded, reflective package such as the **Rox™** RS package in addition to installing adequate radiation shielding around each stage of the dilution refrigerator.

External noise energies

External noise energies that leak into the cryostat and down the leads add to the self-heating of the sensor. Minimizing external noise reaching the sensor is controlled by installation techniques, not the AC bridge. The external noise environment and the response to external noise is different for every installation and may even differ at varying times during the day.

Noise sources and their effects

For the purpose of this document, noise is defined as any signal coupled into the AC resistance bridge circuitry other than the AC excitation signal. Lock-in techniques of AC resistance bridges separate the measurement signal from noise, however, this noise can be coupled into the resistive sensor resulting in sensor heating, thereby contaminating the measurement.

With base temperatures of DRs pushing well below 10 mK, the effect of noise on measurement accuracy becomes increasingly significant. The use of the patented balanced current source in the Model 372 prevents much of the incoming noise from being converted into self-heating energy and is a must-have for sensors operating below 50 mK; however, it is still possible for some sources of noise to make it into the system. Noise sources in any given location will be unique and may couple into a sensitive experiment, especially in a poorly wired and shielded installation.

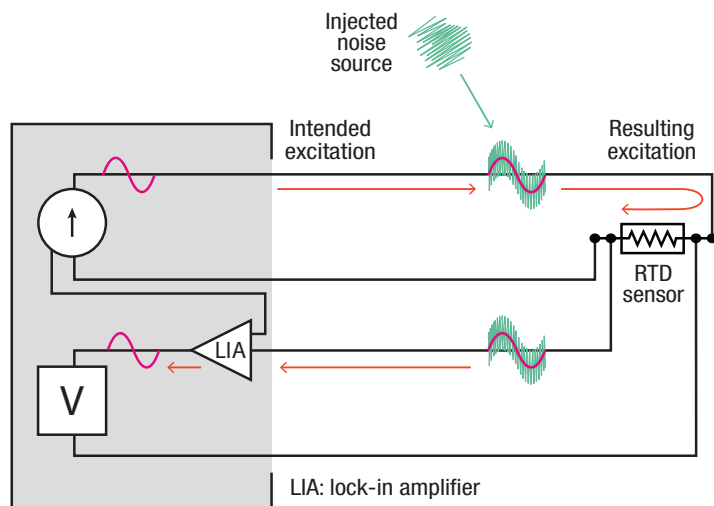

Lock-in technology removes external noise from measurement, but does not protect the sensor from increased self-heating.

Forms of electronic noise signals include:

- **E-field noise** — Capacitive voltage coupling, easily shielded by any “grounded” metal such as a Faraday cage.
- **H-field noise** — Magnetic-field induced current coupling, minimized by twisted-pair wiring and ferrous metals.
- **Vibrational noise** — Mechanically coupled into sensor cables, generating triboelectric signals due to insulating material friction of the shielded cable.

E-field noise sources

E-field noise includes anything from “DC to light” that can be coupled electrostatically (via a parasitic capacitance) into any or all of the four signal lines from an AC bridge to a resistive temperature sensor. Included in this range is “RF” noise, having a frequency range of 1 MHz or more, but the most serious contributor of DR noise is the ubiquitous 50/60 Hz power line noise that pervades the environment from power line sources.

Prior to the development of the Lake Shore Model 370 and later the Model 372, the current sources of nearly all AC bridges were “single-ended,” meaning that the output current was supplied by a single output and referenced to power line “ground,” which was highly susceptible to both ground loops and high-frequency noise.

High-frequency noise

Higher frequency noise sources can react with differing capacitance between each wire of a sensor pair and the shield of the pair. Ideally, capacitance should be the same but minor differences can occur. At higher frequencies, the difference in capacitance causes a difference in resultant coupled noise that can heat the sensor. A system’s susceptibility to higher frequency noise can be detected by using a handheld transceiver (“walkie-talkie”). If the temperature measurement is compromised when a nearby handheld transceiver is transmitting, sensitivity to strong RF signals remains. If proper operation is expected during high frequency noise exposure, additional steps must be taken such as:

- RF filters can be placed on each pair of sensor lines within the cryostat. Contact Lake Shore to discuss possible solutions.
- A shield room can be built around the cryostat.
- Increase the distance from the offending source if possible.

Following these guidelines will provide the maximum protection against unwanted external noise energies and ensure accurate DR temperature readings.

Ground loops — measurement circuits

Grounding the AC bridge chassis (and current source output low) to earth ground was common practice for many years. While intended to meet safety requirements, it was a catastrophe for the elimination of ground loops and accompanying noise currents. No two “grounds” are ever quite the same. Most of the time, within the instrument chassis, the difference is inconsequential. However, there will likely be a significant difference between the instrument chassis ground and the cryostat ground. When the two are connected, there will be 50/60 Hz related noise currents introduced into the sensor wiring.

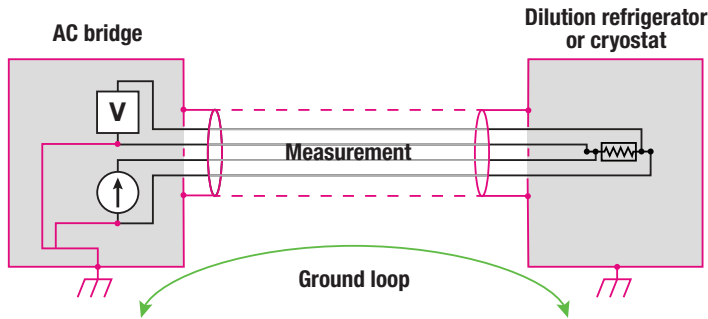

Ground loop created when connecting two grounds at different potentials.

The Lake Shore solution was to design the Model 370/372 AC bridges with an internal “measurement common” front-end circuitry that is galvanically isolated from the rest of the earth-grounded chassis. This breaks the single, most important potential ground loop with no external isolations necessary. The cryostat case becomes measurement common by mounting the 3726 scanner box (the chassis of the scanner is actually measurement common, not earth ground) with metal connecting fasteners to the cryostat itself.

If direct mounting cannot be achieved, a heavy gauge wire connecting the cryostat to the scanner box is mandatory. This method does not force the cryostat to be at some “ground,” but accepts the cryostat’s composite ground and follows it with the galvanically coupled measurement circuitry within the Model 370/372. The Model 370/372 offers a professional way to break the earth ground difference between the earth (power-line) instrument ground and the composite earth ground of the cryostat by following the composite cryostat earth ground internally. All sensor cable shielding is to be 100% foil-shielded up to and including the connectors going inside the cryostat.

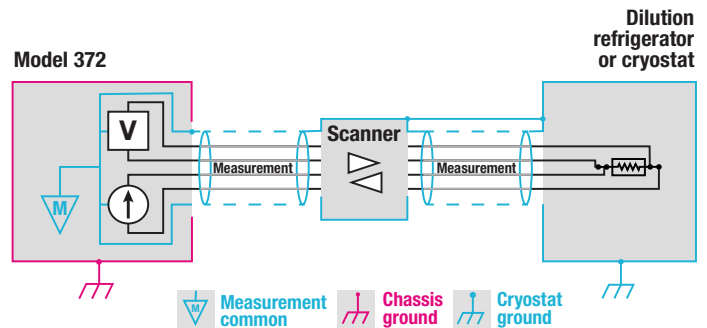

Ground loop avoided by keeping chassis ground separate from measurement common.

Using the monitor output

There is a facility built into the Model 370/372 to help determine a source of noise. The Monitor Output of the Model 370/372 can be selected to output the amplified signal just before internal lock-in action. The Model 370 term “VINMIX” and the Model 372 term “Measurement A/D” are the selections needed for this function. This analog signal should be predominately a sine wave at the frequency selected for AC bridge operation. Viewing this signal on an oscilloscope will quickly reveal the purity of the sine wave as it is compromised by various noise sources. Cable vibration and 50/60 Hz noise is quickly revealed using this technique. Since this output is heavily low-pass filtered below 40 Hz, true RF (radio frequency) noise will be seen only as lower frequency shifts demodulated from the RF envelope and not revealed so much as simply inferred.

Note that this output is referred to as the measurement common of the Model 370/372 and should not be compromised by inadvertent connection to power line ground via the oscilloscope. Most AC-powered oscilloscope signal input grounds are connected to their chassis (power-line derived ground). The oscilloscope must float from power line ground for best measurement. Otherwise, new noise paths may be created just by the connection of the oscilloscope.

Ground loops — heater circuits

Sample heater

Just like the measurement input circuitry of the Model 370/372, the sample heater current output is galvanically isolated from power line ground. The sample heater low side must be connected to a ground or it becomes a potential noise source directing E-field external noise inside the cryostat. The heater cable should be shielded with its shield connected to the cryostat case as well. This is the only heater that should have both its low side and shield connected to the cryostat ground.

Still heater

In the Model 372 only, the still heater shares its isolated low side with the sample heater. If both the still and sample heater are used, only one low-side heater output must be connected to the cryostat. The Model 370 still heater used the chassis ground and had a potential to drive unwanted noise into the system. This was one of the many improvements made between the Model 370 and Model 372.

Warm-up heater

The warm-up heater output circuitry in the Model 372 is capable of sourcing 10 W of power, which can generate some electrical noise. Since the Model 372 is designed to generate as little noise as possible, the warm-up heater is kept on a separate ground to the more sensitive heaters and measurement circuitry. It is grounded to the chassis of the Model 372 when the heater is on, so the low side of the heater should NOT be connected to the cryostat. Only the shield should be connected to the cryostat and this shield should not connect to the Model 372.

If the warm-up heater is not in use, ensure it is set to 'off' so the connection to the chassis ground is cut.

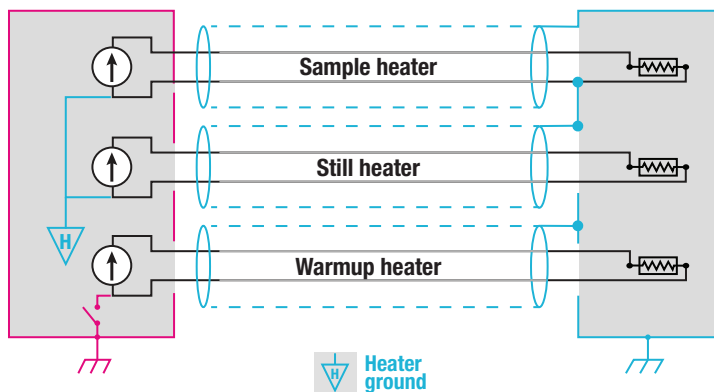

H-field noise sources

H-field noise is AC coupled through magnetic field changes via mutually coupled inductors. Sensor wiring can be considered as a single-turn coil that responds to moving magnetic fields. Sources of moving magnetic fields include pump motors, power transformers of nearby equipment, and deflection yokes from nearby CRT monitors. Basic methods to minimize this coupling include:

- Using twisted-pair sensor wiring external to the cryostat — essential and easily accomplished with readily available, multiple, twisted-pair, foil-shielded cabling.
- Routing multiple sets of cables side by side, or twisted, if possible — this minimizes the size of a potential magnetic “aperture” (the loop area of cable shields connected at both ends) that allows moving magnetic fields to couple and generate currents within the common connected shields.
- Using twisted-pair sensor wiring internal to the cryostat — this is likely more difficult and may not be as influential once inside the cryostat. However, it may be helpful in noisier environments for added resilience. The trade-off in this situation is usually increased difficulty in achieving the excellent thermal anchoring required to minimize heat-leak through the wiring.
- Increasing the distance to the offending source.

Vibrational noise

All electronic cabling from the cryostat to the AC bridge must be free of vibration, isolated from vibrating pumps and plumbing. Vibrating cables become noise sources due to triboelectric signals produced by cable insulation and frictions within the cables. Although these signals are miniscule for many applications, they become large enough to be an issue when looking at μV signals.

System summary

1. Mount the scanner (3708/3726) directly on the DR externally, on the top collar, nearest the connector(s) to internal sensors. If mounting is not practical, use heavy gauge wire from the cryostat to the scanner case. (A screw point is provided on the scanner for this.)
2. Wiring from the scanner to the DR sensor connector(s) should be the shortest practical length of multiple, twisted-pair cable with 100% foil shielding. There should be no break in the measurement shielding.
3. The low side of the sample heater should be connected to the cryostat case as well as the heater. If the still heater is also used, do not connect the low side of this heater to the cryostat case. There should be just one cryostat connection between these two heaters.
4. Keep all electrical connections for the warm-up heater isolated from the cryostat ground. Activate the heater only when needing to warm the system up outside of times when measurement accuracy are needed.
5. Connectors should use all metal housings, electrically connected to the shields of the cabling. Connectors sourced directly from Lake Shore meet these requirements.
6. Use standard Lake Shore cables between the scanner and 370/372 and use a continuously shielded twisted-pair wire between the scanner and cryostat.
7. Minimize cable vibration as much as possible to avoid triboelectric noise.

These simple steps are effective for the majority of 50/60 Hz and relatively low-frequency noise sources.

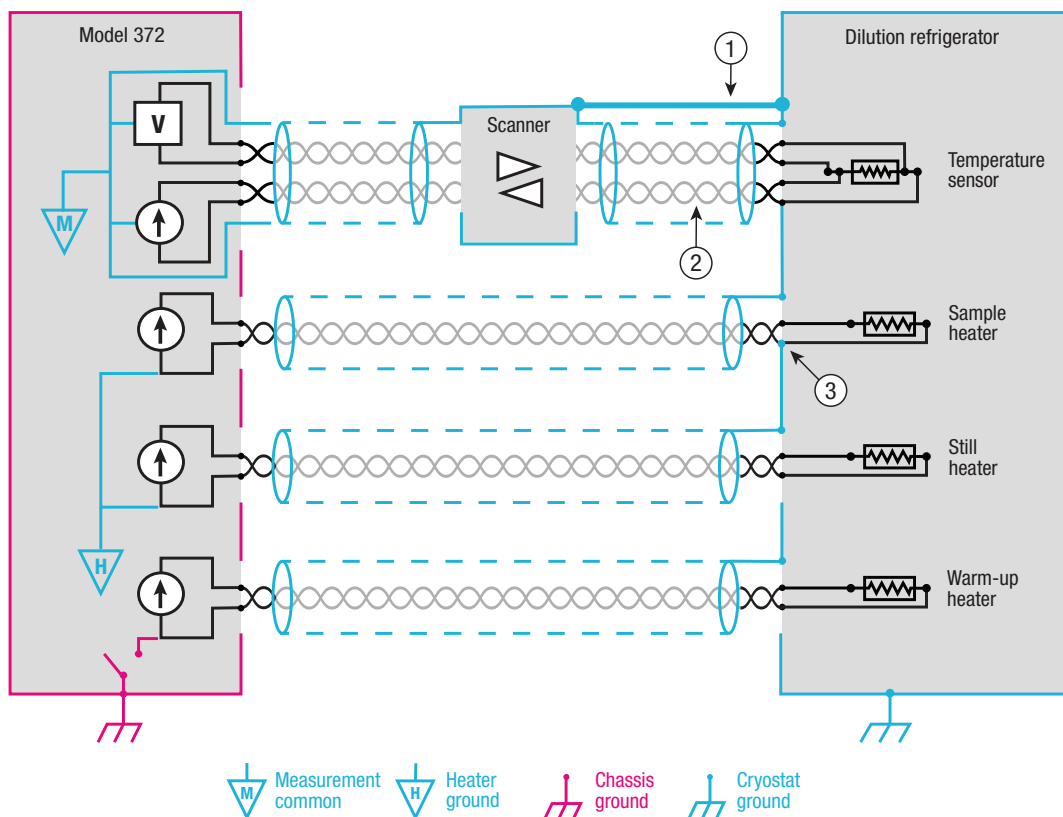

Copyright © Lake Shore Cryotronics, Inc. All rights reserved. Specifications are subject to change.

Lake Shore Cryotronics, the Lake Shore logo, the square graph logomark, and Cernox are registered trademarks of Lake Shore Cryotronics, Inc.

All other trade names referenced are the service marks, trademarks, or registered trademarks of their respective companies.

081721

Questions? Answers?

Visit <http://forums.lakeshore.com/>
and become part of the conversation!



The screenshot shows the Lake Shore Cryotronics User Group Forum interface. At the top left is the Lake Shore CRYOTRONICS logo. Below it is the text "User Group Forum". A navigation bar includes "Home" and "Search" with a search input field and a "Search" button. A breadcrumb trail reads "Lake Shore > Material Characterization Products > Mea". Below this is the text "Talk to fellow users and Lake Shore experts". A "Sub-Boards" section is displayed as a table:

Sub-Boards	
	Board
	I/V source discussion Discuss Lake Shore I/V source applications, rev