

SRP-062B PULSE TUBE

0.5W@4.2K

SHI Cryogenics Group is pleased to announce the highest capacity 0.5W at 4.2K pulse tube in its product line. The SRP-062B improves upon the design of the SRP-062A and offers ultra low vibration thanks to its unique refrigeration concept of no moving parts inside the cold head. The SRP-062B features a concentric design plus a remote valve unit that can be replaced easily, even with the cold head at a low temperature.

The SRP-062B is driven by the new, highly-efficient F-50 compressor. Like all Freedom® series compressors, the F-50 provides refined oil and gas management to the pulse tube and offers a unique 30,000-hour service interval.

Features

- High cooling power allows application in larger systems
- Remote valve unit can be located up to 1m from the cold head
- Concentric design allows easier retrofit into cryostat applications

Specifications

Model:

SRP-062B-F50

Cooling Capacity:

1st stage: 30W at 65K (50/60Hz)

2nd stage: 0.5W at 4.2K (50/60Hz)

Lowest Temperature:

<3.0K

Cooldown Time:

<100/90 minutes (50/60Hz)

Electrical Requirement:

F-50L (low voltage): 3 phase. AC 200V (50/60Hz)

F-50H (high voltage): 3 phase, AC 380, 400V, 415V (50Hz)

3 phase. AC 460V, 480V (60Hz)

Power Consumption:

Steady: 6.5/7.5kW (50/60Hz)

Orientation:

Vertical only

Flexline Length:

20A x 20m or 20A x 6m + buffer tank

Vibration:

2nd stage: ±4 micron

Dimensions and Weight:

Coldhead 604H x 336W x 190L (mm), 23.2 kg

Compressor 591H x 450W x 485L (mm), 120 kg



SRP-062B PULSE TUBE

0.5W@4.2K

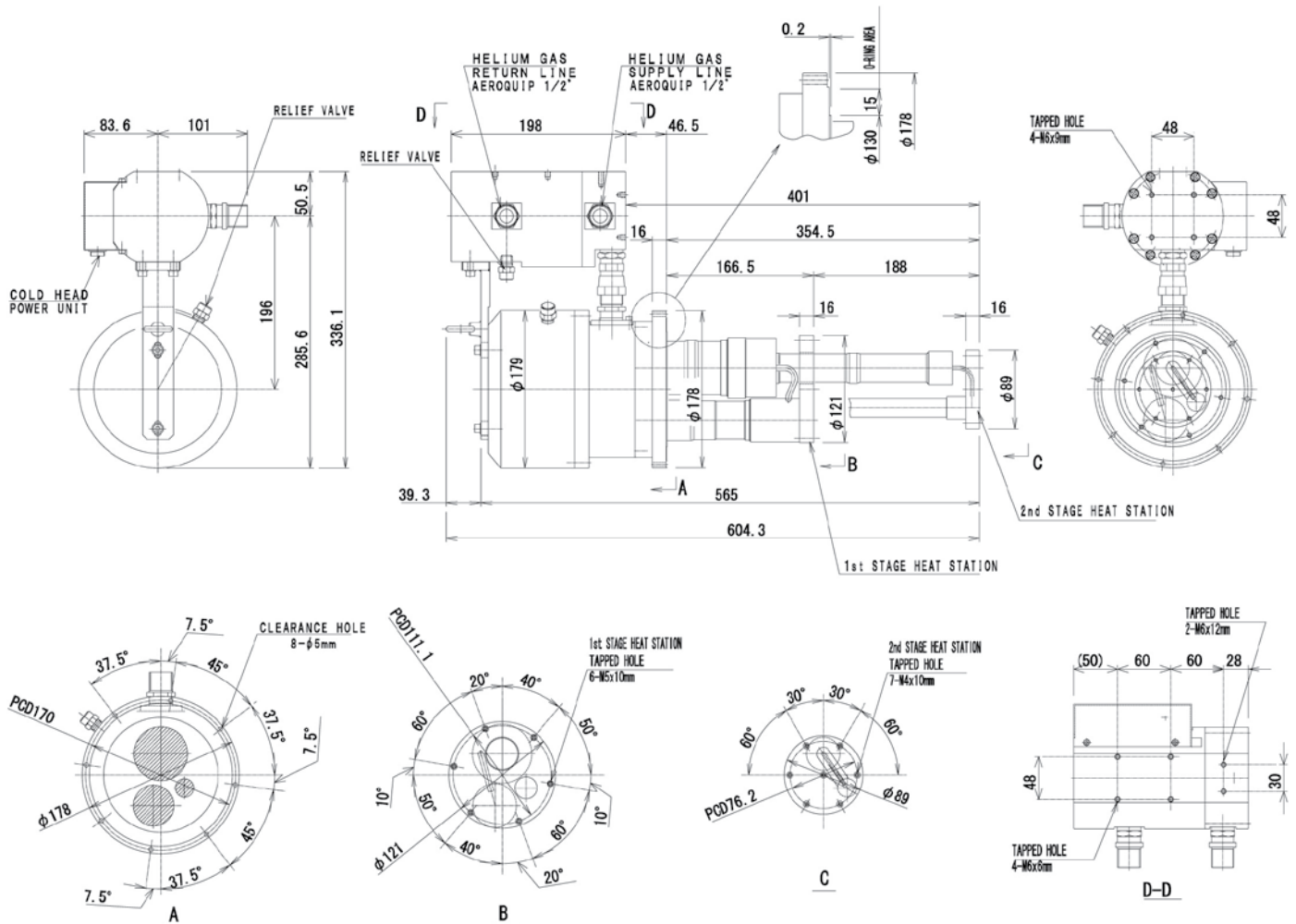

For Information in: Asia

Sumitomo Heavy Industries, Ltd.
Cryogenics Division, Sales Department
1-1, Osaki 2-Chome, Shinagawa-Ku
Tokyo 141-6025, Japan
Phone: +81-3-6737-2550
Fax: +81-3-6866-5114
E-mail: cryo@shi.co.jp

Sumitomo Heavy Industries (Shanghai), Ltd.
Room 2608, Raffles City (Office Tower)
268 Xi Zang Middle Road
Shanghai 200001, P.R. China
Phone: +86 21 6340-3993
Fax: +86 21 6340-3722
E-mail: Jin-Lin_Gao@shi.co.jp

Europe

Sumitomo (SHI) Cryogenics of Europe, Ltd.
3 Hamilton Close, Houndmills Industrial Estate
Basingstoke, Hampshire RG21 6YT
United Kingdom
Phone: +44 (0) 1256 853333
Fax: +44 (0) 1256 471507
E-mail: ukmarketing@shicryogenics.com

Sumitomo (SHI) Cryogenics of Europe GmbH
Daimlerweg 5a
Darmstadt D-64293, Germany
Phone: +49 (0) 6151 860 610
Fax: +49 (0) 6151 800 252
E-mail: contact@sumitomocryo.de

United States

Sumitomo (SHI) Cryogenics of America, Inc.
1833 Vultee Street
Allentown, PA 18103
Phone: +1 610-791-6700
Fax: +1 610-791-0440
E-mail: sales@shicryogenics.com

Sumitomo (SHI) Cryogenics of America, Inc.
456 Oakmead Parkway
Sunnyvale, CA 94085
Phone: +1 408-736-4406
Fax: +1 408-736-7325
E-mail: sales@shicryogenics.com