

MeasureReady™ FastHall™ M91 Breakout Box

M91-TRIAX-DB25

The M91 breakout box allows for the user to easily connect to an M91. The breakout box transposes the triaxial connections of the M91 to a DB25 connector. This allows the user to readily adapt the M91 to equipment that is designed with high density connectors. The breakout box also allows the user to reconfigure the grounding connections to test different methods of making the connection between the M91's source common (output low). See the M91 user's manual for detailed grounding information.



M91 to PPMS connections

a) Sample puck

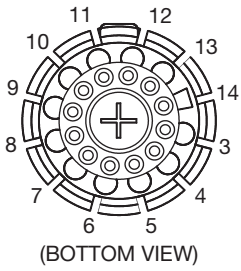

b) Gray LEMO connector

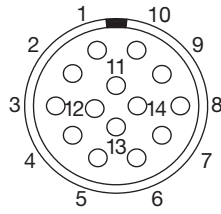

c) P1-user bridge port

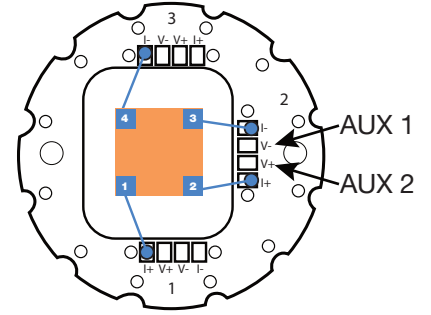
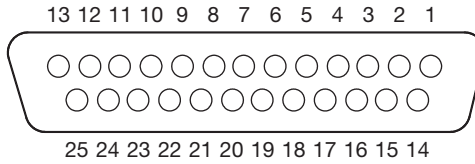

Sample puck	Sample connector	Gray LEMO connector	P1-user bridge 'D' connector	User bridge board function	M91-TRIAx-DB25 connections
			1	Current driver 1+ (unused)	
			14	Current driver 1- (unused)	
			2	Current driver 2+ (unused)	
			15	Current driver 2- (unused)	
3	3	3	5	Channel 1 I+	Triax 1
4	4	4	18	Channel 1 I-	Triax 5
5	5	5	6	Channel 1 V+	Measure common
6	6	6	19	Channel 1 V-	Measure common
7	7	7	7	Channel 2 I+	Triax 2
8	8	8	20	Channel 2 I-	Triax 3
9	9	9	8	Channel 2 V+	Aux 2
10	10	10	21	Channel 2 V-	Aux 1
11	11	11	9	Channel 3 I+	Triax 6
12	12	12	22	Channel 3 I-	Triax 4
13	13	13	10	Channel 3 V+	Measure common
14	14	14	23	Channel 3 V-	Measure common
			11	Channel 4 I+	
			24	Channel 4 I-	
			12	Channel 4 V+	
			25	Channel 4 V-	
			13	Shield (cable)	Measure common/ enclosure (default)

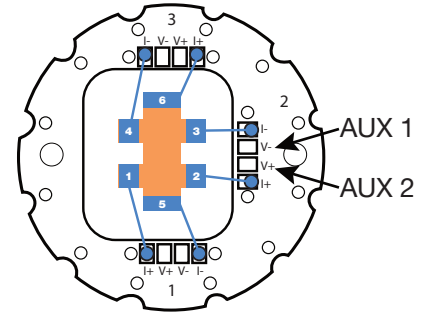

Breakout box schematic

JMP1, JMP2, and JMP3 are installed at Lake Shore. The default jumper configuration (JMP1-3 installed) connect the M91's source common to the enclosure of the breakout box. In a typical system configuration, the breakout box is physically located near the PPMS Dewar and is electrically connected to the Dewar and probe, either through enclosure mounting or ground wire connections. This makes a connection from the M91's source common to chassis. Note: the PPMS user bridge cable's (LEMO to DB25) shield does not typically connect the shell of the DB25 to the cryostat.

To achieve the best noise performance, the M91's source common is typically connected to chassis ground. This can be done either at the back of the M91 or at the system cryostat (Dewar and probe in the PPMS). The connection should be made in only one location. Configuring the jumpers allows the user to test different grounding configurations.

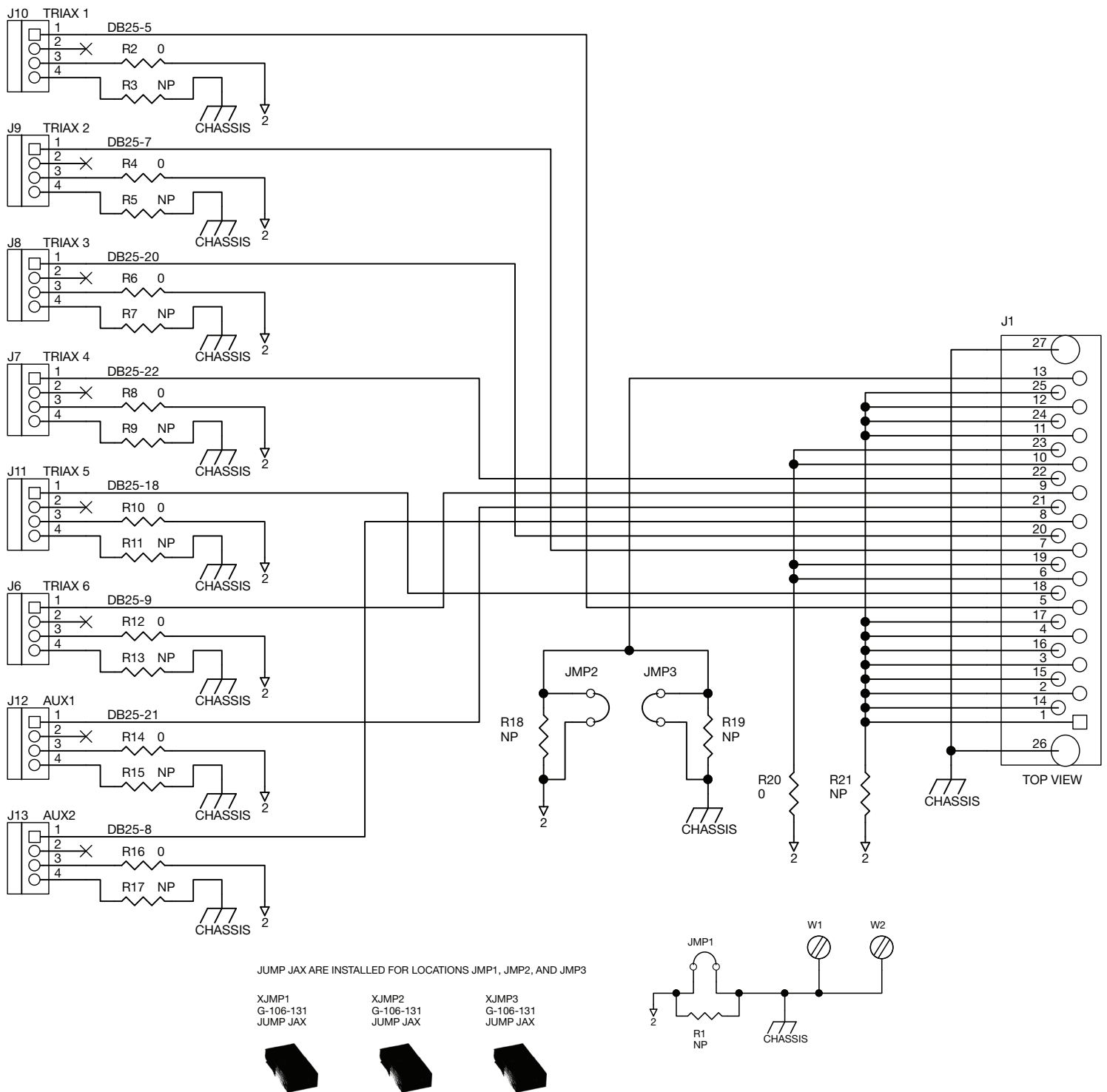

Schematic notes:

- All jumpers installed at Lake Shore.
- Source common (measurement common) can pass from the M91 through the DB25 cable to the puck. See table for details.
- The triaxial outer conductors are insulated from the breakout box enclosure (chassis by default configuration) to enable fully isolated sample connections and to allow the user to determine the ideal single point connection of source common to chassis. Non-populated (NP) resistors are available for test purposes.
- Guards stop at the triaxial connectors on the breakout box. Typically, this is good for resistances of 10 MΩ and lower.
- A non-populated resistor (R21) is available for test purposes. Shorting will connect unused pins in the DB25 to source common.
- Some wires in the user bridge cable (DB25 to LEMO) may not be present.

System grounding

Jumpers	Description	Source common to chassis	Suggested	Breakout box enclosure	DB25 cable shield
JMP1-3 installed	M91 source common connected to breakout box enclosure, DB25 cable shield, and PPMS chassis	M91 rear connection — no PPMS connection — yes	Default configuration	Mounted and wired to PPMS chassis. Connected to source common and chassis.	Connected to source common and chassis
JMP1-3 not installed	M91 source common connected to chassis at M91 rear panel, but not connected in the breakout box enclosure	M91 rear connection — yes PPMS connection — no	Chassis connection at M91 rear panel	Mounted and wired to PPMS chassis. Not connected to source common.	Not connected
JMP1 not installed JMP2 installed JMP3 not installed	M91 source common passes through the breakout box and connected to PPMS chassis at the sample (not connected to breakout box enclosure).	Make connection at M91 rear panel or at PPMS through DB25 pins	Configuration not suggested	Can be isolated or mounted and wired to PPMS chassis. Not connected to source common.	Connected to source common
JMP1 not installed JMP2 not installed JMP3 installed	M91 source common not connected in the breakout box, but the DB25 cable shield is connected to the breakout box enclosure	Make connection at M91 rear panel or at PPMS through DB25 pins	Configuration not suggested	Can be isolated or mounted and wired to PPMS chassis. Not connected to source common.	Connected to breakout box enclosure

Gate bias

The gate bias voltage is typically connected to the sample through AUX 1. An external gate bias voltage source is attached to the M91 breakout box AUX 1 triaxial connector (center pin). This signal is carried through to the puck on Channel 2 V-.

There are two common ways to make gate bias return connections with the M91 breakout box:

1. If the gate bias voltage is referenced to the M91 source common (measurement low), then the gate bias return occurs through the measurement low. Connect the M91 source common (signal return) to the gate bias return (measurement low).
2. If the gate bias return is isolated from chassis, then the gate bias return can be carried back to the voltage source through AUX 2. In this connection method the sample's gate bias return needs to be connected to the puck pin Channel 2 V+.

Dimensions

Weight: 450 g (1 lb)

