



USER'S MANUAL
Model MTD-135
Modular Test Dewar
Cryotest System



Lake Shore Cryotronics, Inc.
575 McCorkle Blvd.
Westerville, Ohio 43082-8888 USA

E-Mail Addresses:
sales@lakeshore.com
service@lakeshore.com

Visit Our Website:
www.lakeshore.com

Fax: (614) 891-1392
Telephone: (614) 891-2243

Methods and apparatus disclosed and described herein have been developed solely on company funds of Lake Shore Cryotronics, Inc. No government or other contractual support or relationship whatsoever has existed which in any way affects or mitigates proprietary rights of Lake Shore Cryotronics, Inc. in these developments. Methods and apparatus disclosed herein may be subject to U.S. Patents existing or applied for. Lake Shore Cryotronics, Inc. reserves the right to add, improve, modify, or withdraw functions, design modifications, or products at any time without notice. Lake Shore shall not be liable for errors contained herein or for incidental or consequential damages in connection with furnishing, performance, or use of this material.

LIMITED WARRANTY

Lake Shore Cryotronics, Inc. (henceforth Lake Shore), the manufacturer, warrants this product to be free from defects in material and workmanship for a period of twelve (12) months from the date of shipment. During the warranty period, under authorized return of instruments or component parts to Lake Shore freight prepaid, the company will repair, or at its option replace, any part found to be defective in material or workmanship, without charge to the Owner for parts, service labor or associated customary shipping cost. Replacement or repaired parts will be warranted for only the unexpired portion of the original warranty.

All products are thoroughly tested and calibrated to published specifications prior to shipment. Calibration Certifications are offered for six month periods only. Where such documentation must be updated, a re-certification service is offered by Lake Shore at a reasonable cost.

LIMITATION OF WARRANTY

This warranty is limited to Lake Shore products purchased and installed in the United States, or Internationally through our approved distribution agents. This same protection will extend to any subsequent owner during the warranty period. It does not apply to damage caused by accident, misuse, fire, flood, or acts of God, from failure to properly install, operate, or maintain the product in accordance with the printed instructions provided. This warranty does not apply to defects resulting from improper or inadequate maintenance, unauthorized modification or misuse, operation outside of the environmental specifications for any product or part or buyer-supplied software interfacing.

This warranty is in lieu of any other warranties, expressed or implied, including merchantability or fitness for a particular purpose, which are expressly excluded. The owner agrees that Lake Shore's liability with respect to this product shall be set forth in this warranty, and incidental or consequential damages are expressly excluded.

CERTIFICATION

Lake Shore certifies that this product has been inspected and tested in accordance with its published specifications and that this product met its published specifications at the time of shipment. The accuracy and calibration of this product at the time of shipment are traceable to the United States National Institute of Standards and Technology (NIST); formerly known as the National Bureau of Standards (NBS).

TRADEMARK ACKNOWLEDGMENT

Many of the designations used by manufacturers and sellers to distinguish their products are claimed as trademarks. Where those designations appear in this manual and Lake Shore was aware of a trademark claim, the designations have been printed in initial capital letters and the [™] or [®] symbol used.

Apiezon[®] is a trademark of Biddle Instruments

Cryo-Gloves[®] is a trademark of Tempshield

Swagelok[®] is a trademark of the Swagelok Company

Teflon[®] is a trademark of DuPont De Nemours

CryoCable[™], Duo-Twist[™], SoftCal[™], Quad-Lead[™], and Quad-Twist[™] are trademarks of Lake Shore Cryotronics, Inc.

Copyright © 1997 – 1999 by Lake Shore Cryotronics, Inc. All rights reserved. No portion of this manual may be reproduced, stored in a retrieval system, or transmitted, in any form or by any means, electronic, mechanical, photocopying, recording, or otherwise, without the express written permission of Lake Shore.

TABLE OF CONTENTS

<i>Chapter/Paragraph</i>	<i>Title</i>	<i>Page</i>
	List of Illustrations	ii
	List of Tables	ii
	Foreword	iii
	Purpose and Scope	iii
	Lake Shore Sensors	iii
	Warning, Cautions, and Notes	iii
	Electrostatic Discharge	iii
	Handling Electrostatic Discharge Sensitive Components	iii
	Handling Cryogenic Storage Dewars	iv
	Safety Summary	iv
	Safety Symbols	iv
1	INTRODUCTION	1-1
1.0	General	1-1
1.1	MTD-135 Cryotest System General Description	1-1
1.2	MTD-135 Cryotest System Features	1-2
1.3	Hardware Descriptions and Functions	1-4
2	INSTALLATION	2-1
2.0	General	2-1
2.1	Inspection and Unpacking	2-1
2.2	Repackaging For Shipment	2-1
2.3	Environmental Requirements	2-1
2.4	System Power and Ground Requirements	2-2
2.5	Physical Support Requirements	2-2
2.6	Liquid Cryogen	2-2
2.7	Instrumentation Hookup Instructions	2-2
2.8	Miscellaneous Precautions	2-3
2.9	Device Under Test (DUT) Insertion	2-3
2.10	Changing the Fanout Board	2-4
2.11	Changing the Test Set Assembly	2-5
3	OPERATION	3-1
3.0	General	3-1
3.1	MTD System Operation	3-1
3.2	MTD System Shutdown	3-3
4	TROUBLESHOOTING	4-1
4.0	General	4-1
4.1	No Cryogen Flow and No Cooling	4-1
4.2	Cryogen Flow But No Cooling	4-1
4.3	Water Condenses On Outer Surface Of Vacuum Chamber	4-1
4.4	Instability in Maintaining Selected Temperature	4-1
4.5	Unable To Reach Cold Terminal Temperature	4-1
4.6	No Response To Control Heater	4-2
4.7	Transfer Lines	4-2
4.7.1	Transfer Line General Precautions	4-2
4.8	Cable Assembly	4-2
5	OPTIONS, ACCESSORIES AND CABLES	5-1
5.0	MTD Cryotest System Options	5-1
5.1	Accessories	5-1

TABLE OF CONTENTS (Continued)

<i>Chapter/Paragraph</i>	<i>Title</i>	<i>Page</i>
A	GLOSSARY OF TERMINOLOGY	A-1
B	UNITS FOR MAGNETIC PROPERTIES.....	B-1
C	TEMPERATURE SCALES.....	C-1
D	TABLE OF ELEMENTS.....	D-1
E	HANDLING OF LIQUID HELIUM AND NITROGEN.....	E-1
E1.0	General.....	E-1
E2.0	Properties.....	E-1
E3.0	Handling Cryogenic Storage Dewars.....	E-1
E4.0	Liquid Helium and Nitrogen Safety Precautions.....	E-2
E5.0	Recommended First Aid.....	E-2

LIST OF ILLUSTRATIONS

<i>Figure No.</i>	<i>Title</i>	<i>Page</i>
1-1	Typical MTD-135 Cryotest System	1-1
1-2	Typical MTD-135 Cutaway.....	1-3
1-3	Typical Fanout Board Wiring	1-4
1-4	10-Pin Instrumentation Feedthrough Connector.....	1-4
1-5	50-Pin Signal Feedthrough Connector.....	1-5
1-6	Vacuum Valve Cutaway.....	1-6
2-1	MTD-135 Hookup to the Model 330 Temperature Controller	2-2
2-2	Retaining Ring and Fanout Board.....	2-4
3-1	Typical MTD-135 Cryotest System Operational Setup	3-1
3-2	Typical Liquid Helium Cooldown Time.....	3-2
4-1	Definition of Model 8271-30M-10 Cable Assembly.....	4-3
C-1	Temperature Scale Comparison.....	C-1
E-1	Typical Cryogenic Storage Dewar.....	E-1

LIST OF TABLES

<i>Table No.</i>	<i>Title</i>	<i>Page</i>
1-1	Model MTD-135 Cryotest System Specifications.....	1-2
B-1	Conversion from CGS to SI Units.....	B-1
B-2	Recommended SI Values for Physical Constants	B-2
C-1	Temperature Conversion Table.....	C-1

FOREWORD

PURPOSE AND SCOPE

This manual contains instructions for the Modular Test Dewar Model MTD-135 Cryotest System. Lake Shore Cryotronics, Inc. designed, manufactures, and assembles the MTD-135 in the United States of America.

We welcome comments concerning this manual. Although every effort has been made to keep it free of errors, some may occur. To report a specific problem, please describe it briefly and include the manual part number, the paragraph/figure/table number, and the page number. Send comments to Lake Shore Cryotronics, Inc. Attn: Technical Publications, 575 McCorkle Blvd., Westerville, Ohio 43082-8888.

LAKE SHORE SENSORS

The MTD-135 Cryotest System uses the Lake Shore Series DT-470 Silicon Diode Temperature Sensor. Sensor installation is covered in detail in the Lake Shore Product Catalog, Application Notes, and Technical Data. Contact Lake Shore for further information.

WARNINGS, CAUTIONS, AND NOTES

Warnings, cautions, and notes appear throughout this manual and always precede the step to which they pertain. Multiple warnings, cautions, or notes are bulleted.

WARNING: An operation or maintenance procedure which, if not strictly observed, may result in injury, death, or long-term health hazards to personnel.

CAUTION: An operation or maintenance procedure which, if not strictly observed, may result in equipment damage, destruction, or loss of effectiveness.

NOTE: Emphasizes an operation or maintenance procedure.

ELECTROSTATIC DISCHARGE

Electrostatic Discharge (ESD) may damage electronic parts, assemblies, and equipment. ESD is a transfer of electrostatic charge between bodies at different electrostatic potentials caused by direct contact or induced by an electrostatic field. The low-energy source that most commonly destroys Electrostatic Discharge Sensitive (ESDS) devices is the human body, which generates and retains static electricity. Simply walking across a carpet in low humidity may generate up to 35,000 volts of static electricity.

Current technology trends toward greater complexity, increased packaging density, and thinner dielectrics between active elements, which results in electronic devices with even more ESD sensitivity. Some electronic parts are more ESDS than others. ESD levels of only a few hundred volts may damage electronic components such as semiconductors, thick and thin film resistors, and piezoelectric crystals during testing, handling, repair, or assembly. Discharge voltages below 4000 volts cannot be seen, felt, or heard.

Identification of Electrostatic Discharge Sensitive Components

Below are various industry symbols used to label components as ESDS:



HANDLING ELECTROSTATIC DISCHARGE SENSITIVE COMPONENTS

Observe all precautions necessary to prevent damage to ESDS components before attempting installation. Bring the device and everything that contacts it to ground potential by providing a conductive surface and discharge paths. As a minimum, observe these precautions:

1. De-energize or disconnect all power and signal sources and loads used with unit.
2. Place unit on a grounded conductive work surface.
3. Ground technician through a conductive wrist strap (or other device) using 1 M Ω series resistor to protect operator.

4. Ground any tools, such as soldering equipment, that will contact unit. Contact with operator's hands provides a sufficient ground for tools that are otherwise electrically isolated.
5. Place ESDS devices and assemblies removed from a unit on a conductive work surface or in a conductive container. An operator inserting or removing a device or assembly from a container must maintain contact with a conductive portion of the container. Use only plastic bags approved for storage of ESD material.
6. Do not handle ESDS devices unnecessarily or remove them from their packages until actually used or tested.

SAFETY SUMMARY

Observe the following general safety precautions during all phases of operation, service, and repair of this instrument. Failure to comply with these precautions or with specific warnings elsewhere in this manual violates safety standards of design, manufacture, and intended use of the instrument. Lake Shore Cryotronics, Inc. assumes no liability for the customer's failure to comply with these requirements.

Ground the Instrument

To minimize shock hazard, connect the instrument chassis and cabinet to an electrical ground. The instrument is equipped with a three-conductor AC power cable. Plug this cable into either an approved three-contact electrical outlet or a three-contact adapter with the grounding wire (green) firmly connected to an electrical ground (safety ground) at the power outlet. The power jack and mating plug of the power cable meet Underwriters Laboratories (UL) and International Electrotechnical Commission (IEC) safety standards.

Do Not Operate in an Explosive Atmosphere

Do not operate the instrument in the presence of flammable gases or fumes. Operating any electrical instrument in such an environment constitutes a definite safety hazard.

Keep Away from Live Circuits

Operating personnel must not remove instrument covers. Refer component replacement and internal adjustments to qualified maintenance personnel. Do not replace components with power cable connected. To avoid injuries, always disconnect power and discharge circuits before touching them.













Do Not Substitute Parts or Modify Instrument

Do not install substitute parts or perform any unauthorized modification to the instrument. Return the instrument to an authorized Lake Shore Cryotronics, Inc. representative for service and repair to ensure that safety features are maintained.

Dangerous Procedure Warnings

A WARNING heading precedes potentially dangerous procedures throughout this manual. Instructions in the warnings *must* be followed.

SAFETY SYMBOLS

	Direct current (power line).		
	Alternating current (power line).		Equipment protected throughout by double insulation or reinforced insulation (equivalent to Class II of IEC 536 - see annex H).
	Alternating or direct current (power line).		Caution: High voltages; danger of electric shock. Background color: Yellow; Symbol and outline: Black.
	Three-phase alternating current (power line).		Caution or Warning - See instrument documentation. Background color: Yellow; Symbol and outline: Black.
	Earth (ground) terminal.		
	Protective conductor terminal.		
	Frame or chassis terminal.		
	On (supply)		
	Off (supply)		

CHAPTER 1

INTRODUCTION

1.0 GENERAL

The MTD-135 Cryotest System provides quality, economically high throughput testing of focal plane arrays and integrated circuits at stable cryogenic test temperatures. The modular design of the MTD systems reduces the time required for test device installation, cycle testing, and test device removal. The MTD systems provide high signal quality as well as quick and easy access to the device test area. See Chapter 6 for options and accessories.

1.1 MTD-135 CRYOTEST SYSTEM GENERAL DESCRIPTION

The MTD-135 System is a cost effective, single test position, 100-lead flexible cryogenic test dewar system configured for rapid production testing of 40-pin dual in-line package (DIP) or 68- or 100-pin leadless chip carrier (LCC) devices at liquid nitrogen (<80 K). The standard system configuration includes a blanked optical window port over the interior device under test (DUT) location. The MTD-135 features a high efficiency, continuous flow, single-stage cryostat which operates with liquid nitrogen (standard) or liquid helium (optional) cryogen. The MTD-135 operates in any orientation. The factory can configure the system to test devices with packages other than the standard 40-pin DIP or 68- or 100-pin LCC package. Consult the factory for details.

The Model MTD-135 is a flexible tool which provides high signal quality, precise temperature control, and rapid test cycling. The unique design of the MTD optimizes test integrity by greatly minimizing the potential for vacuum leaks and signal interference while providing fast, easy access to the test chamber.

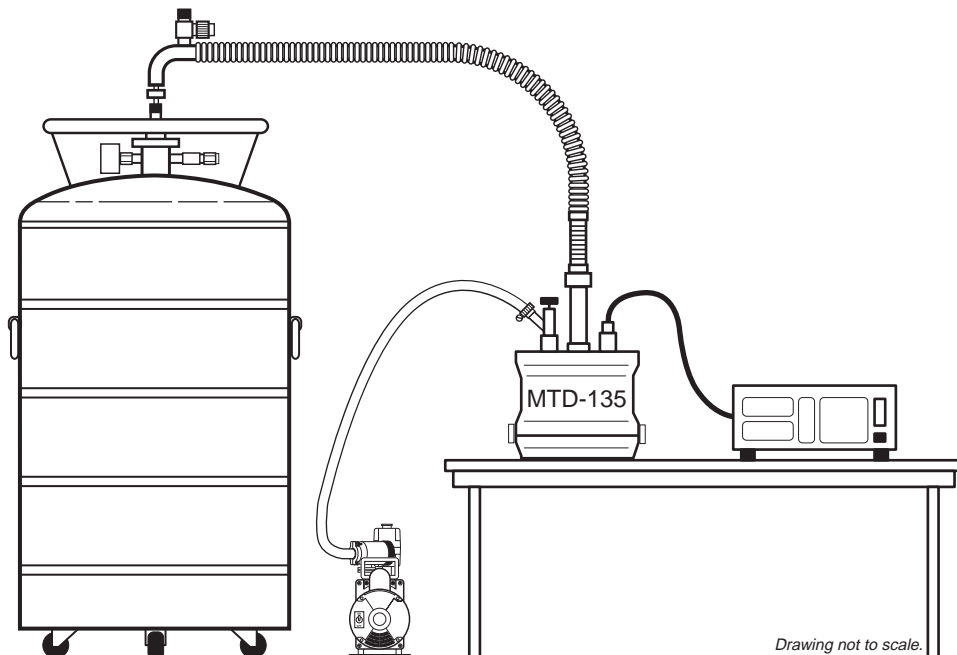

Figure 1-1. Typical MTD-135 Cryotest System Setup

Table 1-1. Model MTD-135 Cryotest System Specifications

Cryotest Mainframe: Integrated single-stage, continuous flow cryostat incorporating a high efficiency heat exchanger for rapid cooling of the sample mounting structure. The radiation shield encloses the DUT area. The cryostat includes a bayonet-style receptacle for a cryogen transfer line and a vacuum pumpout port. The cryostat is designed to use liquid nitrogen (standard) or liquid helium (optional).

Temperature Range: 77–350 K with liquid nitrogen; 10–350 K with liquid helium.

Cool Down Time: About 10 minutes to 80 K (liquid nitrogen); About 20 minutes to 20 K (liquid helium).

Warmup Time: Approximately 20 minutes from cryogenic test temperature to 300 K using a temperature controller with 50 watts of heater output power. The Lake Shore Model 330-11-W50 Autotuning Temperature Controller is recommended.

Stability: ± 0.1 K at the cryogenic test temperatures.

Accuracy: ± 0.5 K from 10 K to 100 K; $\pm 1.0\%$ from 100 K to 350 K

Optical Configuration: The vacuum chamber cover includes an optical window port positioned over the interior DUT location. This port accommodates a 5.1 cm (2 inches) diameter x 6 mm thick window. The nominal focal plane distance to the outside of the window is 3.8 cm (1.5 inches). A 2.54 cm (1 inch) diameter filter can be installed on the radiation shield. The clamp assembly for the DUT accommodates a 2.54 cm (1 inch) diameter filter and aperture. Background flux level is $<10^9$ photons/cm²/second.

Signal Quality: All signal lines are high quality semi-rigid, stainless steel coaxial cabling with solid shielding, 50 Ω characteristic impedance and <15 pfd input capacitance per lead. The 50 Ω impedance is maintained throughout the MTD-135 up to the DUT socket. The signal lines are suitable for bandwidths up to 100 MHz. All interior electrical contacts are gold-plated to enhance contact and inhibit corrosion. Dewar equivalent input noise is approximately 8×10^{-15} A/ $\sqrt{\text{Hz}}$. Cross-talk is less than 0.1% at 1 MHz with the adjacent lead terminated.

Vacuum Performance: System is leak tested at the factory to 10^{-8} cc/sec (standard gaseous helium). Minimum vacuum level requirement before cool down is 10-20 microns. Vacuum pump is user-supplied.

Vacuum Pumpout Port: Standard configuration is a Cryolab 1/2-inch valve, Model S-V8, with 5/8 inch port/removable valve operator. Other configurations are available.

Vacuum Feedthroughs:

- One each 10-pin instrumentation feedthrough for temperature sensor and heater connections.
- Four high density, 25-line/50-pin, 50 Ω impedance feedthroughs for up to 100 signal lines.
- All feedthroughs are located on the base plate of the vacuum chamber.

Cartridge Heaters: One 50 Ω cartridge heater is installed in the MTD-135. The heater is located on the cryostat cold plate for system warmup. All heater lines connect to the 10-pin instrumentation feedthrough.

Size: 18 cm (7 inches) diameter by 30 cm (11.5 inches) long

Weight: 10 kilograms (22 pounds) with gimbal base.

1.2 MTD-135 CRYOTEST SYSTEM FEATURES

Easy access to device test area. The vacuum shroud cover mates to the vacuum shroud body by two spring-loaded, quick-release clamp, with a captive o-ring seal. Beneath the vacuum shroud cover, the radiation shield attaches to the cold stage with captive screws. Remove this radiation shield for quick and simple access to the device test area.

Interchangeable fanout boards accommodate virtually any device package. Fanout boards are designed for three basic purposes: to accept specific device packages and their individual contact arrangement; to reroute contact connections of a device package under prototype test conditions; or to adapt custom-made devices or complete modules.

Convenient, efficient, and economical. The small, easy to handle MTD-135 mounts on an optional gimbal base. It rotates in the base and conveniently locks into any one of 3 positions (up-looking, down-looking, or horizontal). Its small size and highly efficient cryostat ensure the system uses a minimum amount of cryogen for cooldown and device testing.

MTD-135 Cryotest System Features (Continued)

Rapid temperature cycling capability. All MTD systems are built for optimum thermal performance. The MTD-135 is the best choice for small size and high efficiency. It has a single-stage cryostat that cools to cryogenic test temperatures in as little as 10 minutes. For maximum device testing throughput, use a Lake Shore temperature controller with 50 watts of heater output power to rapidly warm the system to room temperature. The Lake Shore temperature controller uses temperature sensors and cartridge heaters installed in all MTD systems. The Lake Shore Model 330-11-W50 Autotuning Temperature Controller is recommended for use with the MTD-135 system.

Superior vacuum characteristics. Instead of penetrating the test chamber with individual feedthroughs, each a potential source for a vacuum leak, the up to 100 coaxial signal lines terminate into four, high-density, 25-line (50-pin) vacuum feedthrough connectors. (Mating connectors are user-supplied.) This configuration reduces discrete penetrations into the vacuum chamber—enhancing test environment integrity.

High signal quality. All MTD systems feature high quality, fully shielded coaxial signal lines with a $50\ \Omega$ characteristic impedance and 15-20 pF of input capacitance ($<15\ \text{pF}$ for the MTD-135 system). The $50\ \Omega$ impedance is maintained throughout the MTD system up to the DUT socket. All interior electrical contact connections are gold-plated to enhance the contact and to inhibit corrosion.

Precise monitoring and control of temperature over a wide range. For temperature measurement and control purposes, temperature sensors (Lake Shore DT-470 Series Silicon Diode Sensors) and cartridge heaters are installed in the MTD system. Lake Shore also offers a complete line of temperature controllers compatible with the MTD systems. The selected Lake Shore temperature controller provides precise temperature measurement and control over the full cryotesting temperature range. The Lake Shore Model 330-11-W50 Autotuning Temperature Controller is recommended for use with the MTD-135. Purchase the temperature controller and cable separately.

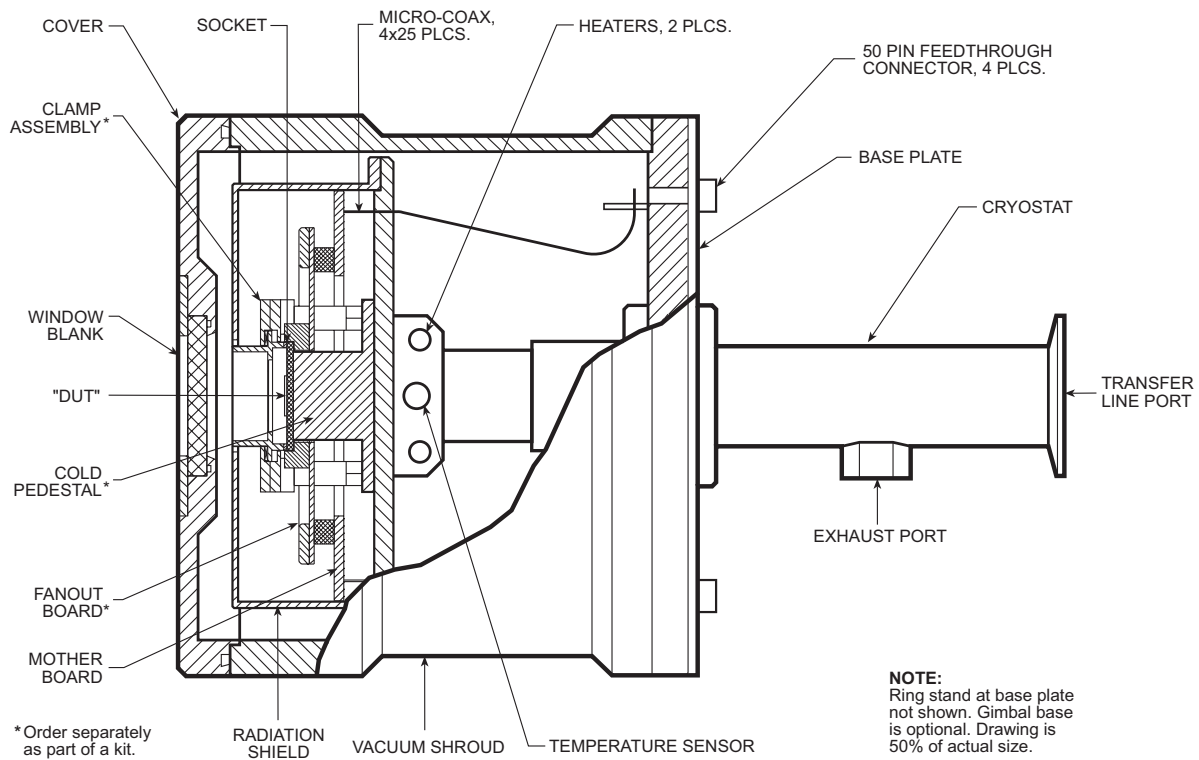

Figure 1-2. Typical MTD-135 Cutaway

1.3 HARDWARE DESCRIPTIONS AND FUNCTIONS

CARTRIDGE HEATER: One 50 Ω cartridge heater is installed in the MTD-135. The heater is located on the cryostat cold stage for system warmup. The heater lines connect to the 10-pin instrumentation feedthrough.

CHIP CARRIER CLAMP ASSEMBLY: Secures chip carrier in the device socket and against the cold pedestal. It may also be used to hold the fixed aperture disks and optical filters. Its spring load ensures good thermal contact between the ceramic substrates on the device package and the cold pedestal.

COLD PLATE AND PEDESTAL: The cold plate provides a cooled mounting surface for the cold pedestal, fanout board, and chip carrier clamp assembly. The cold pedestal provides thermal interface between the DUT and cold plate. It mounts to the center of the cold plate and makes direct thermal contact with the DUT.

CRYOSTAT: Integrated single-stage, continuous flow cryostat incorporating a high efficiency heat exchanger to provide rapid cooling of the sample mounting structure, the radiation shield which encloses the DUT area, and the heat sinks. Designed for either liquid nitrogen or liquid helium cryogen.

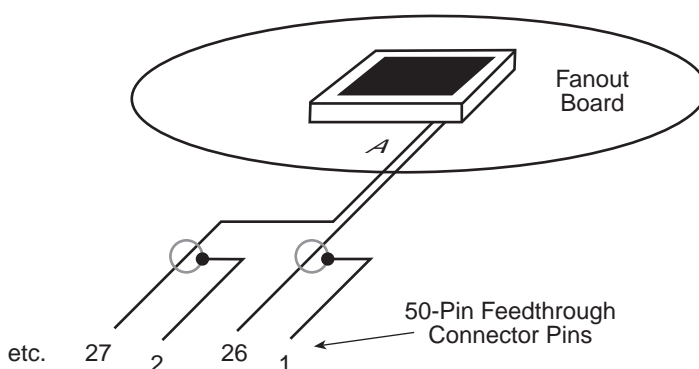

Figure 1-3. Typical Fanout Board Wiring

FANOUT BOARD TEST SET ASSEMBLY: Order the fanout board separately; it is not included with the standard MTD-135 System. The standard fanout board configurations available include the removable 40-pin DIP or 68- or 100-pin LCC device test set assemblies. Each assembly includes all of the hardware necessary to configure the MTD-135 to test the DIP or LCC devices. The assembly includes a fanout board, a chip carrier socket mounted on the fanout board, a chip carrier clamp assembly, and a cold pedestal. The fanout board with the LCC socket and the chip carrier against the cold pedestal can be removed easily from the cold plate and exchanged with another assembly. This clamp housing holds 2.54 cm (1 inch) diameter apertures and/or filters.

INSTRUMENTATION FEEDTHROUGH CONNECTOR: The 10-pin Instrumentation Feed-through Connector is located on the main body of the cryostat. Temperature control and measurement electrical connections are made through the o-ring sealed electrical feedthrough. Only 4 of the 6 pins are used in a standard Model MTD-135 Installation. This allows for future installation of additional instrumentation leads. See Figure 1-4 for connector definition.

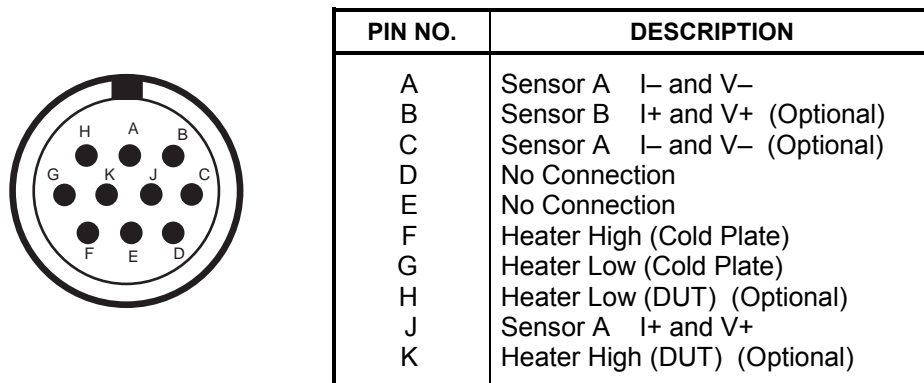

Figure 1-4. 10-Pin Instrumentation Feedthrough Connector

Hardware Descriptions and Functions (Continued)

MICROCOAX CABLING SIGNAL LINES: System configuration is 68 semi-rigid stainless steel microcoax cables with solid shielding which interconnect the hard-wired fanout board and the four 50-pin (25-line) vacuum feedthrough connectors. All 100 coax signal lines are thermally sunk to the cryostat cold plate to reduce heat conduction along signal lines to the DUT area. Coax cable shields electrically float up to their common ground plane interface connection. Ground plane terminations for the coax shields can be isolated upon request.

RADIATION SHIELD: A gold plated radiation shield controls the thermal and optical radiation environment around the device under test. The radiation shield completely encloses the DUT area and attaches to the cold plate with captive screws. With an optional adapter, a 1-inch (2.54 cm) diameter filter/aperture can be mounted on the radiation shield.

SIGNAL FEEDTHROUGH CONNECTOR: Four 50-pin connectors labeled A, B, C, and D pass through the 100 connections from the fanout board. The default setup for a Model MTD-135 is the outer row of 25 pins being the signal lines and the inner row is the shield for that corresponding line (as shown in Figure 1-3). See Figure 1-5 for signal feedthrough connector definition. **Note:** Order mating cables separately.

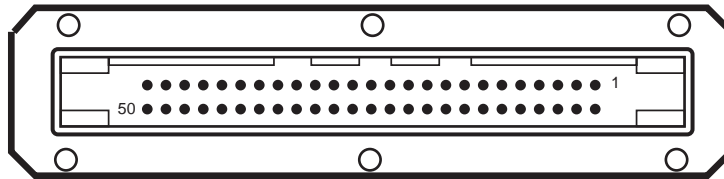

Figure 1-5. 50-Pin Signal Feedthrough Connector

TEMPERATURE SENSOR: One Lake Shore Model DT-470-CU-12A Silicon Diode Cryogenic Temperature Sensor is installed on the MTD-135 cold plate. The sensor measures and controls the DUT temperature and is also utilized during system warmup. It wires to the 10-pin instrumentation feedthrough. For Variable Temperature Test Set, a second sensor and heater are added to the cold pedestal.

VACUUM CHAMBER: Externally black anodized, machined aluminum cylinder which encloses the cryostat cold plate, the signal lines, and the device test area. The complete vacuum chamber consists of a vacuum shroud cover, body, and base plate.

VACUUM CHAMBER BASE PLATE: The vacuum shroud body and cryostat attach to the base plate. All electrical feedthroughs pass through the base plate located on the bottom of the vacuum chamber. The signal line and instrumentation vacuum feedthroughs also mount on the base plate.

VACUUM SHROUD BODY: Main section of the vacuum chamber, mounted to the base plate. Remove vacuum shroud body from the base plate for access to system wiring and mechanical components.

VACUUM SHROUD COVER: Remove the vacuum shroud cover to expose the radiation shield, which encloses the device testing area. The vacuum shroud cover mates to the vacuum shroud body by two (2) spring-loaded, quick release clamp; an o-ring is embedded in the shroud cover to assure a vacuum tight fit between the vacuum shroud cover and body. The cover includes a 5.1 cm (2 inches) diameter x 6 mm window blank over the DUT area.

VACUUM FEEDTHROUGHS: One each 10-pin instrumentation feedthrough for temperature sensor and heater connections. Four high density, 25-line/50-pin, 50 Ω impedance feedthroughs for the 100 signal lines. All feedthroughs are located on the base plate of the vacuum chamber.

Hardware Descriptions and Functions (Continued)

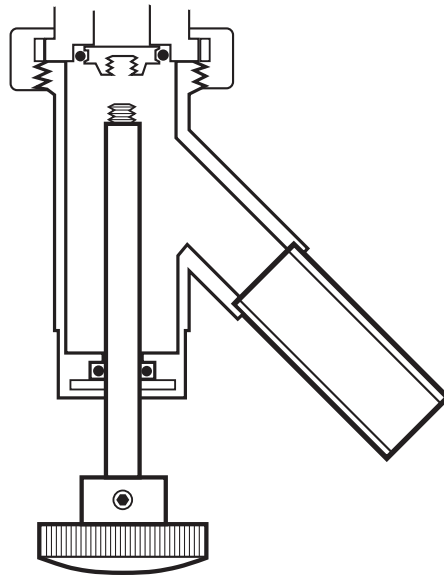

Figure 1-6. Vacuum Valve Cutaway

VACUUM PUMPOUT PORT: Standard configuration is a Cryolab valve with 0.625 inch O.D. tube outlet. Consult factory for other termination options. The vacuum pumpout port connects a vacuum pump to evacuate/isolate vacuum chamber space. It also serves as a pressure relief in case of vacuum chamber overpressure. See Figure 1-6. In normal operation, the handle threads into the valve. The vacuum space may then be manually opened or closed.

CHAPTER 2

INSTALLATION

2.0 GENERAL

This chapter covers various aspects of MTD-135 installation: Inspection and Unpacking (Paragraph 2.1), Repackaging for Shipment (Paragraph 2.2), Environmental Requirements (Paragraph 2.3), System Power and Ground Requirements (Paragraph 2.4), Physical Support Requirements (Paragraph 2.5), Liquid cryogen Requirements (Paragraph 2.6), Instrument Hookup Instructions (Paragraph 2.7), Miscellaneous Precautions (Paragraph 2.8), and the Procedure for Device Under Test (DUT) Insertion (Paragraph 2.9).

2.1 INSPECTING AND UNPACKING

Inspect the shipping container for external damage. Make all claims for damage (apparent or concealed) or partial loss of shipment in writing to Lake Shore within five (5) days from receipt of goods. If damage or loss is apparent, notify the shipping agent immediately.

Open the shipping containers. Locate the MTD-135 packing list and use it to check for receipt of all components, cables, accessories, and manuals. Inspect each item for damage. Retain internal packing material and box for reshipment. Fill out and mail the warranty card.

If there is freight damage to any instruments, promptly file proper claims with the carrier and insurance company and notify Lake Shore Cryotronics. Notify Lake Shore of any missing parts immediately. Lake Shore cannot be responsible for any missing parts unless notified within 60 days of shipment. See the standard Lake Shore Cryotronics, Inc. Warranty on the A Page (immediately behind the title page).

2.2 REPACKAGING FOR SHIPMENT

To return any part of the MTD-135 for repair or replacement, obtain a Return Goods Authorization (RGA) number from a factory representative before returning the instrument to our service department. When returning an instrument for service, Lake Shore requires the following information before attempting any repair:

1. Instrument model and serial number
2. User's name, company, address, and phone number
3. Malfunction symptoms
4. Description of system
5. Returned Goods Authorization number

Consult the factory for shipping instructions. Ship the MTD-135 in the original shipping box.

2.3 ENVIRONMENTAL REQUIREMENTS

Operate the MTD-135 in an area with an ambient temperature range of 18 to 28 °C (64.4 to 82.4 °F). The unit may be operated within the range of 15 to 35 °C (59 to 95 °F) with reduced accuracy.

The MTD-135 is intended for laboratory use: no specific humidity or altitude specifications have been determined. However, relative humidity of 20 to 80 percent (no condensation) and altitudes from sea level to 2.4 km (8,000 feet) are generally acceptable.

WARNING: To prevent electrical fire or shock hazards, do not expose this instrument to moisture.

Provide adequate ventilation. See Forward for cryogenic safety instructions. Filter dust and other particulate matter at the site to a reasonable level. For salt air, corrosive gases, or other air pollutants, consult an air-conditioning expert for special filtering arrangements.

2.4 POWER AND GROUND REQUIREMENTS

Regulate the frequency and voltage of the AC power source for components associated with the MTD-135 and isolate it from sources that may generate Electromagnetic Interference (EMI). The MTD-135 system is designed for single-phase 3-wire alternating current (AC) power; do not use two-wire (without ground) AC power. Lake Shore recommends Ground Fault Interrupter (GFI) and Transient Surge Protection circuitry at the AC source. For voltage variation, consider using a constant voltage transformer. For power outages, consider using an Uninterruptible Power Supply (UPS).

2.5 PHYSICAL SUPPORT REQUIREMENTS

Stabilize the MTD to prevent the system from tipping over or falling, especially during transfer of liquid cryogen. The preferred method for the MTD-135 is to clamp the mounting base to the table surface.

2.6 LIQUID CRYOGEN

The Model MTD-135 Cryostat uses either liquid nitrogen (standard) or liquid helium (optional, order transfer line separately).

2.7 INSTRUMENTATION HOOKUP INSTRUCTIONS

It is recommended the MTD-135 be used with the Model 330 Autotuning Temperature Controller. Figure 2-1 details the Model 8271-30M-10 Cable Assembly hookup to the Model 330. See Figure 4.1 for cable assembly definition.

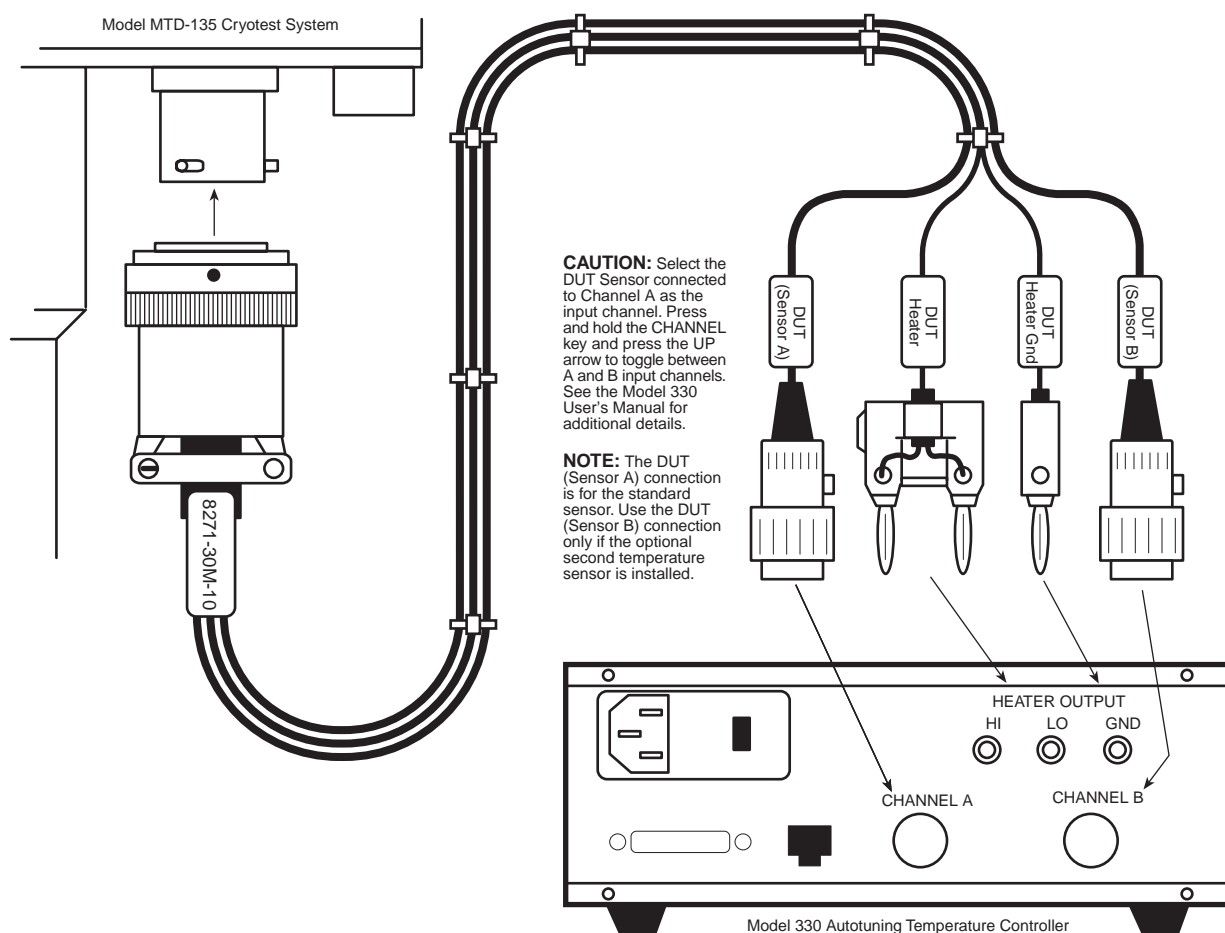

Figure 2-1. MTD-135 Hookup to the Model 330 Temperature Controller

2.8 MISCELLANEOUS PRECAUTIONS

Installation personnel shall observe all safety regulations at all times. Keep away from live circuits. Turn off system power before making or breaking electrical connections. Regard any exposed connector, terminal board, or circuit board as a possible shock hazard. Discharge charged components only when such grounding cannot damage equipment. If a test connection to energized equipment is required, make the test equipment ground connection before probing the voltage or signal.

Do not install or service equipment alone. Do not under any circumstances reach into or enter any enclosure to service or adjust equipment without the presence or assistance of another person able to render aid.

These recommended general safety precautions are unrelated to any specific procedure and do not appear elsewhere in this manual. Personnel should understand and apply these precautions during installation.

- When necessary, evacuate the transfer line with a nitrogen-trapped diffusive-type vacuum system.
- Do not bend the transfer line to a radius less than 12 inches (30 cm).
- Heater power should not exceed 80 watts.
- Never heat the DUT mount or any part of the MTD-135 above 100 °C.
- Do not “break” vacuum in the chamber while the system is cold.
- Do not “break” transfer line vacuum with helium gas.
- Avoid contact with cold gas when depressurizing the storage dewar.
- Periodically clean routinely accessed o-ring seals and their mating surfaces with a paper wipe and re-grease with Apiezon[®] “N” grease.

2.9 DEVICE UNDER TEST (DUT) INSERTION

1. Stabilize the MTD-135 System at room temperature and remove the transfer line.
2. Open the cryostat vacuum pumpout valve to vent system.
3. Release the 2 pull-down clamps and remove the vacuum chamber enclosure.

NOTE: Place vacuum chamber enclosure with the o-ring face up to prevent damage.

4. Remove radiation shield by unscrewing the six captive socket head screws.
5. Remove the chip carrier clamp assembly held in place by 4 captive socket head screws.
6. Place the DUT in the device socket on the fan out board and ensure that its contacts line up with the socket contacts.
7. Carefully place the chip carrier clamp assembly over the DUT and check that it compresses the DUT into the socket without binding.
8. Replace the chip carrier clamp assembly mounting screws in a 1–3–2–4 sequence to ensure uniform clamping pressure.

CAUTION: Do not over tighten screws or completely tighten one at a time. Tighten each screw $\frac{1}{2}$ turn, continuously repeating the 1–3–2–4 sequence until all four screws are snug.

9. Replace the radiation shield.
10. Clamp down the vacuum chamber enclosure.

2.10 CHANGING THE FANOUT BOARD

NOTE: Stabilize the MTD-135 System at room temperature and remove the transfer line.

1. Perform steps 1 through 5 from Paragraph 2.9.
2. Remove the fanout board retaining ring held in place by 4 phillips flat head screws.
3. Remove fanout board. Take care; protect the spring finger contacts exposed by fanout board removal.

NOTE: Some test set assemblies (such as the Model 1520-24D, 24-pin DIP with Zero Insertion Force socket) have additional mounting screws that hold the cold pedestal adapter piece in the center of the device socket. Remove these screws also.

4. Install the fanout board so that the cold pedestal protrudes through the device socket.

CAUTION: Cold pedestal and fanout board must not bind. Do not force socket over cold pedestal.

5. Replace the fanout board retaining ring with the 4 flat head screws.
6. Place the DUT in the device socket on the fanout board and ensure that its contacts line up with the socket contacts.
7. Carefully place the chip carrier clamp assembly over the DUT and check that it compresses the DUT into the socket without binding.
8. Replace the chip carrier clamp assembly mounting screws in a 1–2–3–4 sequence to ensure uniform clamping pressure.

CAUTION: Do not over tighten mounting screws or completely tighten one at a time. Tighten each screw one-half turn, continuously repeating the 1–3–2–4 sequence until all four screws are snug.

9. Replace the cooled filter wheel assemblies, if used, and tighten the 3 captive screws and the drive shaft collet lock hex nut. Verify proper alignment of filters/apertures.
10. Replace the radiation shield.
11. Clamp down the vacuum chamber end closure.

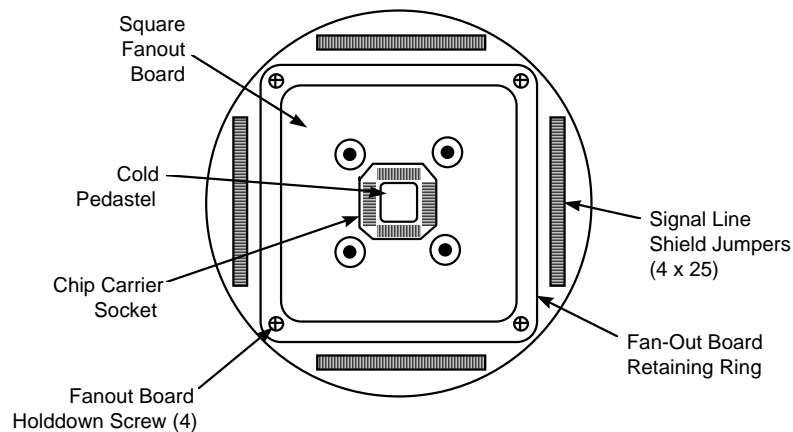

Figure 2-2. Retaining Ring and Fanout Board

2.11 CHANGING THE TEST SET ASSEMBLY

This procedure is necessary when switching a DIP (Dual In-Line Package), LCC (Leadless Chip Carrier), or other device that requires a different fanout board and socket.

NOTE: Stabilize the MTD-135 System at room temperature and remove the transfer line.

1. Follow steps 1 through 3 in Paragraph 2.10.
2. Remove the 4 gold plated posts which hold the cold pedestal in place.

CAUTION: Handle the gold plated aluminum posts with care. The threads may be easily damaged.

3. Remove the cold pedestal.

NOTE: It may be necessary to gently pry the cold pedestal base from the cold plate. The indium foil at the thermal interface tends to stick to the mated surfaces.

4. Clean with rubbing alcohol and a paper wipe the cold plate surface where the cold pedestal contacts the cold plate. Verify the cold pedestal base plate is also clean.
5. Cut 0.07 – 0.127 mm (0.003 – 0.005 inch) thick indium foil to the shape of the cold pedestal base plate.
6. Fasten cold pedestal to cold plate (with the indium foil placed carefully between the surfaces) using the 4 gold plated posts supplied with the test set assembly kit. Also, be sure to use the Belleville spring washers.

CAUTION: Do not over tighten the posts and remember to handle with care.

7. Install the fanout board so that the cold pedestal protrudes through the device socket.

CAUTION: Cold pedestal and fanout board must not bind. Do not force socket over cold pedestal.

8. Replace the fanout board retaining ring with the 4 phillips flathead screws.
9. Place the DUT in the device socket on the fanout board and ensure that its contacts line up with the socket contacts.
10. Carefully place the chip carrier clamp assembly over the DUT and check that it compresses the DUT into the socket without binding.
11. Replace chip carrier clamp assembly mounting screws in a 1–2–3–4 sequence to ensure uniform clamping pressure.

CAUTION: Do not over tighten mounting screws or completely tighten one at a time. Tighten each screw one-half turn, continuously repeating the 1–2–3–4 sequence until all four screws are snug.

12. Replace the cooled filter wheel assemblies, if used, and tighten the 3 captive screws and the drive shaft collet lock hex nut. Ensure that the filters/apertures are properly aligned.
13. Replace the radiation shield.
14. Clamp down the vacuum chamber end closure.

This Page Intentionally Left Blank

CHAPTER 3

OPERATION

3.0 GENERAL

This chapter describes MTD-135 Cryotest System operation (Paragraph 3.1) and shutdown (Paragraph 3.2). Read the entire manual before continuing, and verify all instruments work correctly prior to system operation.

3.1 MTD SYSTEM OPERATION

1. To evacuate vacuum chamber, attach suitable nitrogen-trapped vacuum pumping system capable of 20 millitorr to vacuum port. Turn on vacuum pump.
2. Slowly open cryostat vacuum pumpout valve. A clean system reaches 20 millitorr in 15 to 20 minutes.

CAUTION: Do not pump on MTD System when cold or contamination from pumping system may “cryopump” onto cold surfaces. Do not vent and back fill system with gas during warm-up.

3. Fully close valve pumpout valve and disconnect vacuum line.
4. To initiate cryogen flow into MTD, attach a nitrogen or helium gas line to transfer line at bayonet fitting end and purge transfer line with gas. Gas exits at line flow valve.
5. Close transfer line flow valve using full counter-clockwise rotation when looking down at the knob.

CAUTION: Do not over tighten flow valve. Over-tightening may damage the valve seat.

6. Remove gas line from transfer line.
7. Slowly insert transfer line withdrawal tube into storage dewar.
8. Open transfer line flow valve 1 to 2 turns.

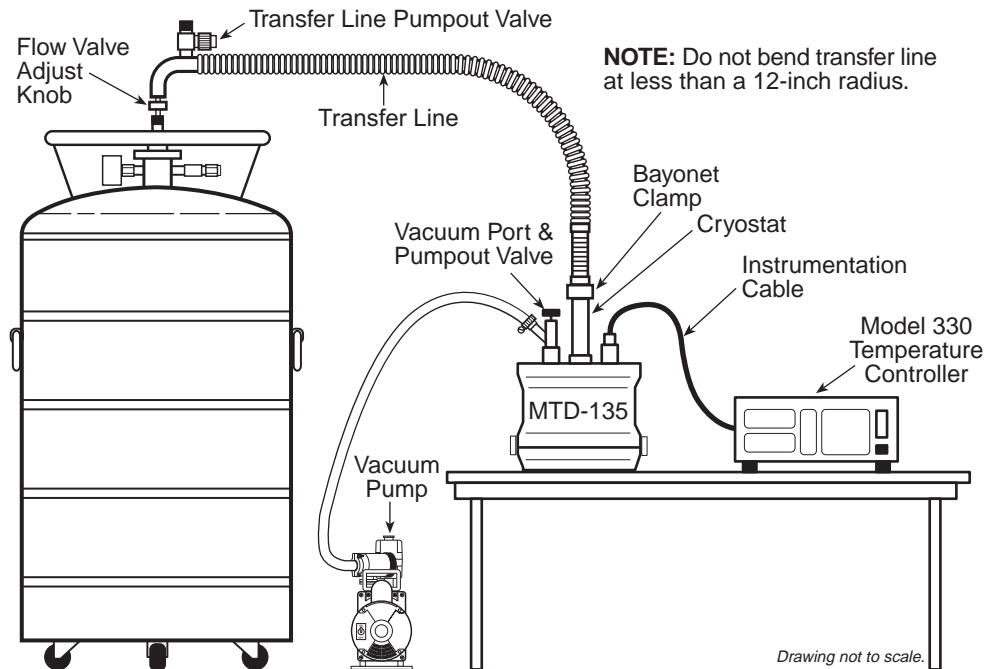
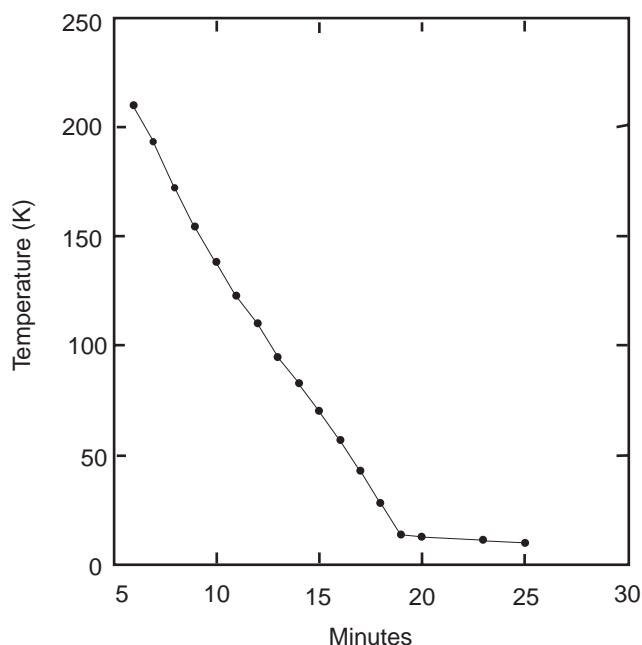

Figure 3-1. Typical MTD-135 Cryotest System Operational Setup

MTD System Operation (Continued)

9. Seal storage dewar to allow pressure buildup. Actual seal depends on storage dewar used. Standard seal is a 1/2 inch compression fitting which provides gas seal and supports withdrawal tube.
10. Attach gas pressurizing hose to proper pressurizing provision on storage dewar. (If using a pressure hat, this would be 3/8 O.D. tube soldered or welded to hat.)
11. Set pressure regulator to between 3 and 8 psi.
12. After 3-4 minutes, cold gas begins to escape at bayonet end.
NOTE: If more than 5 minutes elapses with no cold gas escaping, there may be an ice plug in the line. Depressurize the storage dewar and pull the withdrawal tube out of it. Warm transfer line with a heatgun, then purge it with dry helium gas. (See Chapter 4 if attempting a warm-start cool down and there appears to be no gas flow.)
13. When cold gas begins escaping from transfer line bayonet fitting, insert it into MTD cryostat bayonet receptacle and secure with bayonet clamp.
NOTE: Ensure rubber bayonet seal is installed before securing the bayonet clamp.
14. Connect Model 8271-30M-10 Instrumentation Cable to 10-pin instrumentation feedthrough connector located on underside of the MTD-135 vacuum chamber.
15. Connect other end of Instrumentation Cable to Sensor A on the rear of the Temperature Controller. See Figure 2-1 for hookup to the Model 330 Autotuning Temperature Controller. Consult the Model 330 Temperature Controller User's Manual for controller operation.
CAUTION: Verify the proper sensor is connected to the temperature controller control input channel and the correct heater plug is connected to the controller output. Improper connections may cause damage due to applying heater power to one stage while sensing temperature on the other stage.
16. Wait for MTD System to cool down to desired temperature. Typical liquid helium cooldown times are shown in Figure 3-2. Typical Liquid nitrogen cooldown times are about 10 minutes to 80 K. Once temperature is reached, throttle back flow of cryogen. (One-half turn open is sufficient in most cases.)

**Figure 3-2. Typical Liquid Helium Cooldown Time**

MTD System Operation (Continued)

17. Adjust setpoint on Temperature Controller to desired value. Temperature Controller applies current to heaters installed in the cold stage to maintain temperature at a specified setpoint. Consult Application Note *Fundamentals For Usage of Cryogenic Temperature Controllers* normally included in Temperature Controller User's Manual for setting proportional, integral and derivative (PID) constants.
18. To connect Customer instrumentation to the DUT signal lines, connect appropriate cables to four 50-pin feedthrough connectors on vacuum chamber base plate. Connectors are labeled A, B, C, and D. A typical 50-pin connector is illustrated in Figure 1-4. The MTD-135 is now ready to perform tests.

NOTE: Although the instrumentation connectors have 50 pins, there are only 25 signal lines per connector—25 signal lines × 4 connectors = 100 connections on the fanout board. When viewing the instrumentation connector as shown in Figure 1-5, the outer row of 25 pins for signals from the DUT. The inner row of 25 pins has connections for the shields. The shield pin corresponds to the signal pin directly adjacent to it.

NOTE: Other wiring configurations are possible per Customer Order. Consult the factory with questions concerning alternative wiring configurations.

3.2 MTD SYSTEM SHUTDOWN

At the completion of the test, the steps below ensure proper system shutdown and avoid contamination of the DUT by water vapor or other contaminants.

1. Close transfer line flow valve to stop cryogen flow.

CAUTION: Do not overtighten the flow valve. Over-tightening may damage the valve seat.

2. Disconnect transfer line from MTD cryostat bayonet receptacle. Remove transfer line.
3. Immediately cap MTD bayonet receptacle with blank flange. Use rubber seal between flange surfaces.
4. Slowly depressurize storage dewar before removing withdrawal tube.

NOTE: Follow proper helium handling procedures. Refer to Appendix E – Handling of Liquid Helium and Nitrogen for further information.

5. Slowly remove withdrawal tube from storage dewar. Allow it to warm to prevent o-ring seal from freezing.
6. Wipe all moisture from transfer line withdrawal tube and bayonet coupling.

NOTE: In order to prevent condensation of moisture, do not open the MTD System until all internal parts are at room temperature. Because the MTD is designed to be thermally efficient, this will take several hours without assistance.

NOTE: Do not vent and back-fill system with gas for a rapid warm-up.

This Page Intentionally Left Blank

CHAPTER 4

SERVICE

4.0 GENERAL

This chapter covers possible difficulties that may occur. Read the entire manual before attempting to service the MTD-135 System. Please contact the factory with any questions or concerns.

4.1 NO CRYOGEN FLOW AND NO COOLING

During a warm start cool down, latent heat must be removed from the transfer line. Therefore, the flow rate may be low during this "flat" period and difficult to observe. Allow sufficient time (5 minutes) to make sure that there is no flow before following the procedure below. If there is no cryogen flow and no cooling there may be frozen air or moisture inside the system.

1. Depressurize the storage dewar.
2. Remove the transfer line withdrawal tube from the storage dewar and allow the tube to warm.
3. Attach a helium gas line to the transfer line and purge the transfer line with helium gas for 3-5 minutes.
4. Close the transfer line flow valve using (full counter-clockwise rotation when looking down at the knob).
5. Remove helium gas line from the transfer line.

4.2 CRYOGEN FLOW BUT NO COOLING

If sufficient time has passed to complete the normal "flat" period and there is cryogen flow but no cooling, check the transfer line vacuum integrity. It may be necessary to re-evacuate the transfer line. If the transfer line vacuum is "good," check the vacuum in the MTD-135 vacuum chamber. The vacuum chamber should not feel cold.

4.3 WATER CONDENSES ON OUTER SURFACE OF VACUUM CHAMBER

If the vacuum chamber "sweats," check the vacuum integrity of the chamber.

4.4 INSTABILITY IN MAINTAINING SELECTED TEMPERATURE

If using an automatic temperature controller, verify gain setting is not too high. Verify there are no electric shorts to the sensors and heaters.

4.5 UNABLE TO REACH COLD TERMINAL TEMPERATURE

This may be caused by any of the following:

- Experimental heat load too high.
- Improper anchoring of instrumentation and DUT lines or poor wiring practices.
- "Soft" vacuum in the vacuum chamber or transfer line.
- Thermal short between DUT and radiation shield or radiation shield and vacuum chamber.
- Poor interfacing between DUT and mount and/or between temperature sensor and cold finger.
- Insufficient cryogen flow rate.

4.6 NO RESPONSE TO CONTROL HEATER

Check the cables to the 10-pin instrumentation feedthrough located on the cryostat main body, the power supply, and controller. Check the heater lines with an ohmmeter. If approximately 50Ω are not measured, verify correct wiring. Otherwise, replace the heater. Consult the factory for instructions.

4.7 TRANSFER LINES

Lake Shore transfer lines ship with the vacuum jacket evacuated to ensure a clean vacuum space. As a precaution against vacuum deterioration which arises sometimes during transit or prolonged storage, re-evacuate the vacuum jacket prior to use. Use a cold-trapped rotary/diffusion pumping station capable of a pressure of approximately 10^{-5} Torr. After evacuation, firmly close the Vacuum Port Pumpout valve. Do not overtighten; it may damage the valve seat. Disconnect and remove the valve operator.

When evacuation is initiated, ensure pressure on the pump side of the evacuation valve is less than the vacuum space pressure to avoid drawing pump oil vapor into the vacuum space. Do not pump the vacuum jacket while liquid helium passes through the inner line; the liquid helium may cryopump to a lower pressure than the pumping station in use.

The transfer line withdrawal tube has a built-in activated charcoal getter to help maintain good vacuum when inserted in cryogen. Maintain this space under vacuum at all times and never allow helium gas or moist air into this space. If moisture or helium accidentally enters the space, attach a pumping station to the space for several days to bring pressure down to an acceptable level.

On completion of an experiment, close the needle valve at the bottom of the transfer line withdrawal tube, and place a one way (or pressure relief) valve at the vacuum port on the MTD. This prevents cryogen from reaching the DUT mount and air or moisture from entering the inner line region. Any cryogen remaining in the inner line vents safely outside the cryostat. De-pressurize the storage dewar and remove the withdrawal tube to reduce heat input into the liquid inside the dewar.

4.7.1 Transfer Line General Precautions

Maintain a vacuum in the transfer line at all times, and re-evacuate it whenever it feels colder than normal during transfer. Evacuate while the inner line is at room temperature. Never allow helium gas or moist air into the vacuum jacket.

- Do not bend the transfer line to a radius of less than 12 inches (30 cm).
- Do not overtighten the needle (flow control) valve at the bottom of the withdrawal tube.
- An anti-oscillation device on the helium storage dewar is recommended. Keep the end of the withdrawal about one centimeter above the bottom of the storage dewar.

4.8 CABLE ASSEMBLY

Details of the optional Cable Assembly P/N 8271-30M-10 that connects a MTD-135 with a Lake Shore Model 330 Autotuning Temperature Controller appear in Figure 4-1.

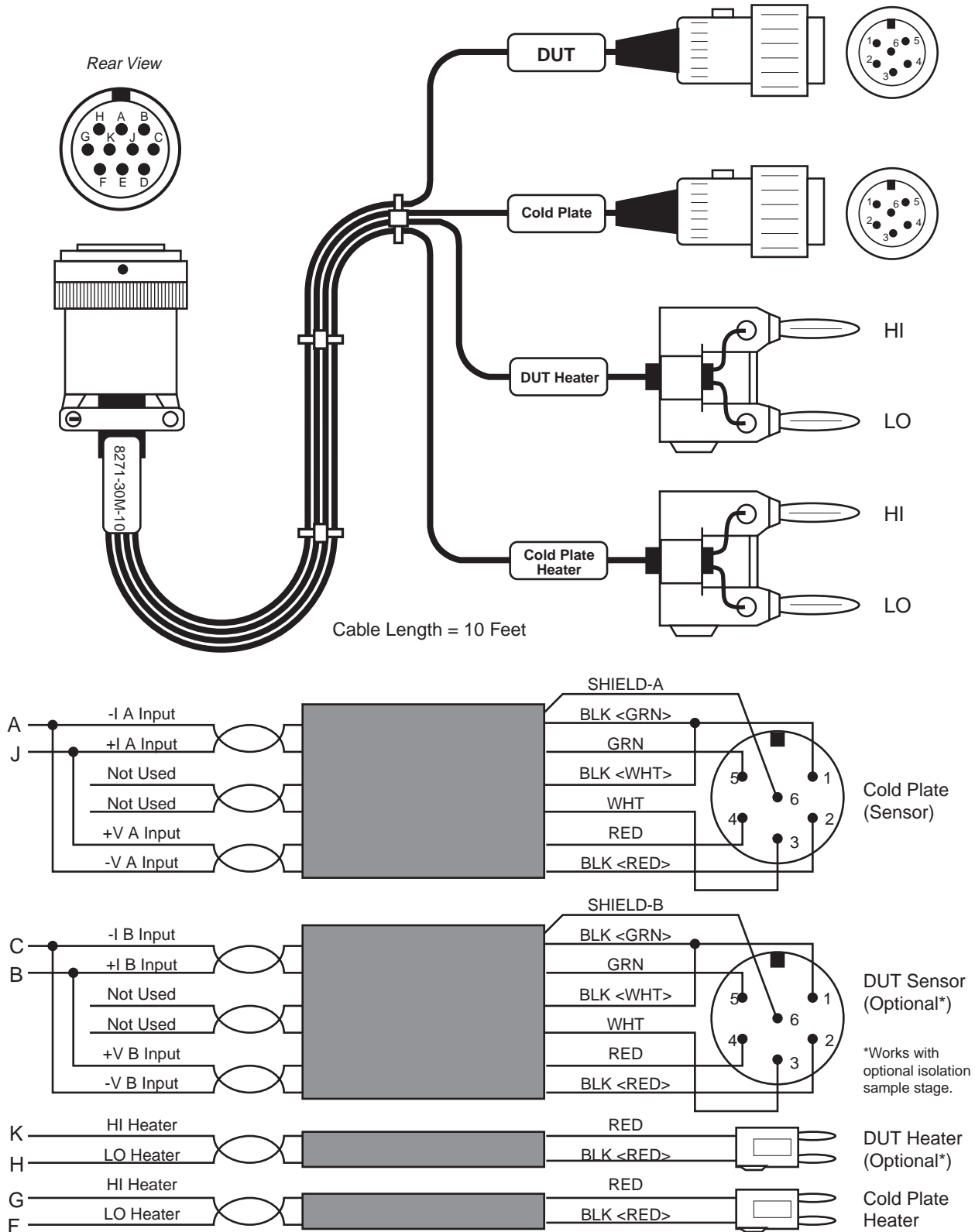

Figure 4-1. Definition of Model 8271-30M-10 Cable Assembly

This Page Intentionally Left Blank

CHAPTER 5

OPTIONS AND ACCESSORIES

5.0 MTD CRYOTEST SYSTEM OPTIONS

Lake Shore tailors the MTD Cryotest System to fit custom applications. Contact Lake Shore for details.

5.1 ACCESSORIES

Accessories are devices that perform a secondary duty as an aid or refinement to the primary unit. Add other accessories not listed (signal cable assemblies, breakout boxes, filters/apertures, etc.) as required. Consult the factory for current availability of other accessories not listed below.

MODEL NUMBER	DESCRIPTION OF ACCESSORY
1065	Breakout Module with 25 BNC Connectors. Breakout modules attach directly to the MTD System and contain 25 coax BNC connectors, which correspond to one side (or quadrant) of the device package. The 1065 mounts directly to the multiple line feedthroughs on the baseplate of the vacuum chamber. This configuration eliminates the need for an interconnecting cable, reducing potential noise pickup and parasitic capacitance.
1150K-40D	Variable Temperature Test Set Assembly Kit – 40-pin DIP. Kit includes Cold Pedestal, Fanout Board, Top Clamp, and fasteners.
1150K-68	Variable Temperature Test Set Assembly Kit – 68-pin LCC. Kit includes Cold Pedestal, Fanout Board, Top Clamp, and fasteners.
1150K-100	Variable Temperature Test Set Assembly Kit – 100-pin LCC. Kit includes Cold Pedestal, Fanout Board, Top Clamp, and fasteners.
1205	Liquid Helium/Liquid Nitrogen Transfer Line. This conventional, flexible vacuum-insulated line has a long, rigid withdrawal tube for insertion into a liquid helium storage vessel or modified liquid nitrogen container. May be used to operate MTD System in continuous flow mode. Withdrawal tube has a filter to prevent foreign matter from plugging the small diameter inner tube, and an integral valve assembly to control cryogen flow. The other end of the transfer line terminates in a bayonet fitting which easily mates to the MTD-100 liquid transfer cooling unit. The transfer line vacuum space is fitted with a vacuum pumpout valve and safety pressure relief valve.
1210	Liquid Nitrogen Transfer Line. Flexible vacuum-insulated line for transferring LN ₂ from a pressurized storage dewar to an MTD System. May be used to operate MTD in continuous flow mode. Consists of a 1 meter (3 foot) withdrawal tube for insertion into a modified liquid nitrogen container. The withdrawal tube has a filter to prevent foreign matter from plugging the small diameter inner tube, and an insulated valve assembly to control cryogen flow. The other end of the transfer line terminates in a bayonet fitting which easily mates to the MTD liquid transfer cooling unit.
1215	Liquid Nitrogen Precooling Transfer Line. Flexible stainless steel transfer line quickly and economically pre-cools an MTD System to about 80 K with LN ₂ before cooling the system to 5 K with more costly LHe.

Accessories (Continued)

MODEL NUMBER	DESCRIPTION OF ACCESSORY
1220-50	<p>Liquid Nitrogen 50-Liter Storage Dewar. Rugged, self-pressurized dewar compatible with the Model 1210 and 1215 Transfer Lines. The top port accommodates the transfer line 1/2 inch rigid withdrawal tube which siphons LN₂ (the same withdrawal process commonly used with laboratory LHe storage dewars). Permanent vacuum insulation and multilayer reflective shielding with getter materials ensure normal LN₂ evaporation losses of <1.5 liters per day. The polished stainless steel dewar comes with a 1/2 inch fill and withdrawal valve, a 3/8 inch vent valve, and a liquid level gauge. Mounted on casters for easy mobility.</p> <p>Liquid Capacity: 50 liters Outside Diameter: 18 inches Overall Height: 42 inches Loss Rate: 1.5 liters per day, maximum Overall Height: 42 inches Operating Pressure: 10 psi, maximum Pressure Gauge: 0 – 30 psig Connections: Fill and Withdrawal: 1/2 inch male flare Vent: 3/8 inch male NPT Weight: Empty: 100 pounds; Full: 180 pounds; Shipping: 150 pounds Transfer Line Port: 1/2 inch I.D.</p>
1325	<p>Filter Wheel Assembly – 5 position. Accepts quantity of five 1-inch diameter filters, up to 0.1 inch thick.</p>
1550	<p>Fanout Boards: Interconnect the Device Under Test (DUT) to the coax signal lines (via the interface board) in the MTD System. The socket for a particular device package is mounted on the fanout board and the socket contacts are soldered to the board traces. The fanout board 50Ω gold plated stripline transmission traces enhance electrical connections and inhibit corrosion. The Model 1550 Series fanout boards/DIP boards may be configured with any commonly used chip carrier sockets. Will accommodate zero insertion force, DIP (to 64-pin capacity) devices, or 68-, 84-, or 100-pin LCCs. Custom package configurations also available. Consult Lake Shore for details.</p> <p>1550-40Z - For 40-pin Zero Insertion Force (ZIF) devices 1550-xxD - For DIP devices (“xx” up to 64 pin maximum) 1550-68 - For 68-pin LCC devices 1550-84 - For 84-pin LCC devices 1550-100 - For 100-pin LCC devices</p>
1550K	<p>Device Test Set Assembly Kit: Includes a fanout board/DIP fanout board with any commonly used chip carrier sockets, chip carrier clamp assembly, and cold finger pedestal - all gold plated. The clamp assembly positions the chip carrier against the cold pedestal and holds the fixed aperture disks and optical filters. A 1-inch (2.54 cm) diameter aperture disk with one or two cold filters inserts in the optical path and is held in place by a screw-on cap with a 0.8 inch (2.93 cm) aperture. All interior optical surfaces are vapor-blasted and black-anodized to minimize optical reflections. Order the test set assembly kit separately from the basic MTD system mainframe. Each test set accommodates the standard or modified fanout board/chip carrier socket arrangement you require. One test set is required per MTD mainframe. Consult Lake Shore for details.</p> <p>1550K-40Z - For 40-pin Zero Insertion Force (ZIF) devices 1550K-xxD - For DIP devices (“xx” up to 64 pin maximum) 1550K-68 - For 68-pin LCC devices 1550K-84 - For 84-pin LCC devices 1550K-100 - For 100-pin LCC devices</p>
1550-X	<p>DT-470 sensor and chip heater pre-mounted in a Customer-Supplied Leadless Chip Carrier (LCC) Mounting Base. Lake Shore service for those who want an existing LCC mounting base configured with a temperature sensor and heater. This accessory normally uses a Lake Shore Model DT-470-SD-12 silicon diode temperature sensor. Contact Lake Shore for further information.</p>

Accessories (Continued)

MODEL NUMBER	DESCRIPTION OF ACCESSORY																								
1551	<p>Personality Fanout Boards: Circuit traces interrupted and terminated in bifurcated pins, offering a means to reroute contact connections. Consult Lake Shore for details.</p> <p>1551-40Z - For 40-pin Zero Insertion Force (ZIF) devices</p> <p>1551-xxD - For DIP devices (“xx” up to 64 pin maximum)</p> <p>1551-68 - For 68-pin LCC devices</p> <p>1551-84 - For 84-pin LCC devices</p> <p>1551-100 - For 100-pin LCC devices</p>																								
1551K	<p>1551K – Device Test Set Assembly Kit: Includes the Model 1551 personality fanout boards with specific device socket, a clamp assembly, and the appropriate cold finger pedestal - all gold painted. The clamp assembly positions the chip carrier against the cold pedestal and holds the fixed aperture disks and optical filters. A 1-inch (2.54 cm) diameter aperture disk with one or two cold filters inserts in the optical path and is held in place by a screw-on cap with a 0.8 inch (2.93 cm) aperture. All interior optical surfaces are vapor blasted and black-anodized to minimize optical reflections. Order the test set assembly kit separately from the basic MTD system mainframe. Each test set accommodates the standard or modified fanout board/chip carrier socket arrangement you require. One test set is required per MTD mainframe. Consult Lake Shore for details.</p> <p>1551K-40Z - For 40-pin Zero Insertion Force (ZIF) devices</p> <p>1551K-xxD - For DIP devices (“xx” up to 64 pin maximum)</p> <p>1551K-68 - For 68-pin LCC devices</p> <p>1551K-84 - For 84-pin LCC devices</p> <p>1551K-100 - For 100-pin LCC devices</p>																								
1620	<p>Four 25-Lead Ribbon Cables: One meter (3 feet) cables terminated with Insulation Displacement Contact (IDC) 50-pin (0.1 x 0.1 inch spacing) female socket headers on both ends. The female socket headers are compatible with the male sockets in the 1025 Breakout Box and the 25-line/50-pin vacuum feedthrough connectors on all MTD models. Compatible with the Model 1025 Breakout Box and 25-line/50-pin vacuum feedthrough connectors on most MTD Systems.</p> <table border="0" data-bbox="402 1144 1463 1486"> <tr> <td data-bbox="402 1144 971 1171">MECHANICAL SPECIFICATIONS:</td> <td data-bbox="987 1144 1463 1171">ELECTRICAL SPECIFICATIONS:</td> </tr> <tr> <td data-bbox="402 1171 971 1199">Center Conductor: 28 AWG (0.08-0.09 mm²) Cu</td> <td data-bbox="987 1171 1463 1199">Impedance: 50 ±3 Ohms</td> </tr> <tr> <td data-bbox="402 1199 971 1226">Insulation Coating: Alkyd Enamel</td> <td data-bbox="987 1199 1463 1226">Capacitance: 31 pF/ft (304.8) nom.</td> </tr> <tr> <td data-bbox="402 1226 971 1253">Dielectric: Polypropylene</td> <td data-bbox="987 1226 1463 1253">Crosstalk Constant* (Adjacent Pair):</td> </tr> <tr> <td data-bbox="402 1253 971 1281">Dielectric: Constant: 2.3 nom.</td> <td data-bbox="987 1253 1463 1281">Far End 2%, Near End 4%</td> </tr> <tr> <td data-bbox="402 1281 971 1308">Shield: Al Mylar Foil 0.00135 (0.03429) thick</td> <td data-bbox="987 1281 1463 1308">Crosstalk Constant* (All Other Lines):</td> </tr> <tr> <td data-bbox="402 1308 971 1335">Drain Conductor: 28 or 30 AWG</td> <td data-bbox="987 1308 1463 1335">Far End 0%, Near End 0%</td> </tr> <tr> <td data-bbox="402 1335 971 1362">(0.09-0.05) mm² Tin Plated Cu</td> <td data-bbox="987 1335 1463 1362">Propagation Delay: <1.6 ns/ft. (304.8)</td> </tr> <tr> <td data-bbox="402 1362 971 1390">Jacket: PVC (Fr)</td> <td data-bbox="987 1362 1463 1390">Risetime Degradation (20-80%):</td> </tr> <tr> <td data-bbox="402 1390 971 1417">Color per EAI STD RS-359: Black</td> <td data-bbox="987 1390 1463 1417">400 ps/10 Ft (305 m)</td> </tr> <tr> <td data-bbox="402 1417 971 1444">Centerline Spacing: 0.100 (2.54)</td> <td data-bbox="987 1417 1463 1444">Attenuation (at 100 MHz): <14 dB/100 ft</td> </tr> <tr> <td></td> <td data-bbox="987 1444 1463 1472">(30.48 m)</td> </tr> </table>	MECHANICAL SPECIFICATIONS:	ELECTRICAL SPECIFICATIONS:	Center Conductor: 28 AWG (0.08-0.09 mm ²) Cu	Impedance: 50 ±3 Ohms	Insulation Coating: Alkyd Enamel	Capacitance: 31 pF/ft (304.8) nom.	Dielectric: Polypropylene	Crosstalk Constant* (Adjacent Pair):	Dielectric: Constant: 2.3 nom.	Far End 2%, Near End 4%	Shield: Al Mylar Foil 0.00135 (0.03429) thick	Crosstalk Constant* (All Other Lines):	Drain Conductor: 28 or 30 AWG	Far End 0%, Near End 0%	(0.09-0.05) mm ² Tin Plated Cu	Propagation Delay: <1.6 ns/ft. (304.8)	Jacket: PVC (Fr)	Risetime Degradation (20-80%):	Color per EAI STD RS-359: Black	400 ps/10 Ft (305 m)	Centerline Spacing: 0.100 (2.54)	Attenuation (at 100 MHz): <14 dB/100 ft		(30.48 m)
MECHANICAL SPECIFICATIONS:	ELECTRICAL SPECIFICATIONS:																								
Center Conductor: 28 AWG (0.08-0.09 mm ²) Cu	Impedance: 50 ±3 Ohms																								
Insulation Coating: Alkyd Enamel	Capacitance: 31 pF/ft (304.8) nom.																								
Dielectric: Polypropylene	Crosstalk Constant* (Adjacent Pair):																								
Dielectric: Constant: 2.3 nom.	Far End 2%, Near End 4%																								
Shield: Al Mylar Foil 0.00135 (0.03429) thick	Crosstalk Constant* (All Other Lines):																								
Drain Conductor: 28 or 30 AWG	Far End 0%, Near End 0%																								
(0.09-0.05) mm ² Tin Plated Cu	Propagation Delay: <1.6 ns/ft. (304.8)																								
Jacket: PVC (Fr)	Risetime Degradation (20-80%):																								
Color per EAI STD RS-359: Black	400 ps/10 Ft (305 m)																								
Centerline Spacing: 0.100 (2.54)	Attenuation (at 100 MHz): <14 dB/100 ft																								
	(30.48 m)																								
1630	<p>Socket/BNC Cable Assembly: One meter (3 feet) of coaxial ribbon cabling with connectors on each end provides convenient BNC connections to individual signal lines in an MTD System. On one end is 50-pin female socket header which mates with the 25-line/50-pin vacuum feedthroughs for the signal lines on all MTD Systems. The other end has 25 individual female BNCs attached to the 25 coax lines of the ribbon cable. The center pin is the conductor and case is the shield. Electrical and mechanical specifications are as listed for the Model 1620.</p>																								
1707	<p>Gimbal Base Assembly. Pivots an MTD system on the gimbal's horizontal support axis for placement in a down-looking, up-looking, or horizontal orientation. Construction is 12.7 cm (0.5 inch) aluminum plate with black-anodized finish.</p>																								
330-11-50W	<p>Model 330 Autotuning Temperature Controller. A full featured digital control unit featuring Autotuning and SoftCal™. Consult the Lake Shore Product Catalog for details.</p>																								

Accessories (Continued)

MODEL NUMBER	DESCRIPTION OF ACCESSORY
340	Model 340 Autotuning Temperature Controller. A full featured digital control unit featuring Autotuning and SoftCal™. Consult the Lake Shore Product Catalog for details.
8271-30M-10	Instrumentation Interconnection Cable for Model 330 Autotuning Temperature Controller.
9001-00X	Lake Shore Cryogenic Wire. Lake Shore sells the following types of cryogenic wire: DT = Duo-Twist™, MN = Single Strand, MW = Manganin, NC = Nichrome Heater, ND = Heavy Duty, QL = Quad-Lead™, and QT = Quad-Twist™. See Lake Shore Catalog for details.
9002-432	CryoCable™ 4 x 32 AWG. A robust, 4-wire superconductive cable for use in applications ranging from cryogenic to room temperature. Designed by Lake Shore for Customers with demanding installations. Available in 25, 50, and 100 foot lengths.
9004-020	Apiezon® “N” Grease, 25 gram Tube. General purpose grease well-suited for cryogenic use because of its low viscosity. Often used as a means of thermally anchoring cryogenic sensors as well as lubricating joints and o-rings. Contains high molecular weight polymeric hydrocarbon additive which gives it a tenacious, rubbery consistency that cushions mating surfaces.
9005-016	19-Pin Vacuum Feedthrough Connector With Flange.
9007-002	Indium Foil (5 Pieces). Indium is a semi-precious non-ferrous metal, softer than lead, and extremely malleable and ductile. It stays soft and workable down to cryogenic temperatures. May be used as a sealing gasket for covers, flanges, and windows in cryogenic applications.
PS-R2010	Vacuum Pump. Pumps out sample space before cooling.
PS-EXT70	Vacuum Pump. Versatile cryogenic pump station. Pumps out dewar, transfer line, and all other vacuum spaces.

APPENDIX A

GLOSSARY OF TERMINOLOGY

absolute zero. The temperature of $-273.15\text{ }^{\circ}\text{C}$, or $-459.67\text{ }^{\circ}\text{F}$, or 0 K , thought to be the temperature at which molecular motion vanishes and a body would have no heat energy.¹

accuracy. The degree of correctness with which a measured value agrees with the true value.²

electronic accuracy. The accuracy of an instrument independent of the sensor.

sensor accuracy. The accuracy of a temperature sensor and its associated calibration or its ability to match a standard curve.

Alumel™. An aluminum-nickel alloy which comprises the negative lead of a Type K thermocouple.

American Wire Gage (AWG). Wiring sizes are defined as diameters in inches and millimeters as follows:

AWG	Dia. In.	Dia. mm	AWG	Dia. In.	Dia. mm	AWG	Dia. In.	Dia. mm	AWG	Dia. In.	Dia. mm
1	0.2893	7.348	11	0.0907	2.304	21	0.0285	0.7230	31	0.0089	0.2268
2	0.2576	6.544	12	0.0808	2.053	22	0.0253	0.6438	32	0.0080	0.2019
3	0.2294	5.827	13	0.0720	1.829	23	0.0226	0.5733	33	0.00708	0.178
4	0.2043	5.189	14	0.0641	1.628	24	0.0207	0.5106	34	0.00630	0.152
5	0.1819	4.621	15	0.0571	1.450	25	0.0179	0.4547	35	0.00561	0.138
6	0.1620	4.115	16	0.0508	1.291	26	0.0159	0.4049	36	0.00500	0.127
7	0.1443	3.665	17	0.0453	1.150	27	0.0142	0.3606	37	0.00445	0.1131
8	0.1285	3.264	18	0.0403	1.024	28	0.0126	0.3211	38	0.00397	0.1007
9	0.1144	2.906	19	0.0359	0.9116	29	0.0113	0.2859	39	0.00353	0.08969
10	0.1019	2.588	20	0.0338	0.8118	30	0.0100	0.2546	40	0.00314	0.07987

ambient temperature. The temperature of the surrounding medium, such as gas or liquid, which comes into contact with the apparatus.¹

ampere. The constant current that, if maintained in two straight parallel conductors of infinite length, of negligible circular cross section, and placed one meter apart in a vacuum, would produce between these conductors a force equal to 2×10^{-7} newton per meter of length.² This is one of the base units of the SI.

ampere-turn. A MKS unit of magnetomotive force equal to the magnetomotive force around a path linking one turn of a conducting loop carrying a current of one ampere; or 1.26 gilberts.

ampere/meter (A/m). The SI unit for magnetic field strength (H). 1 ampere/meter = $4\pi/1000$ oersted ≈ 0.01257 oersted.

analog controller. A feedback control system where there is an unbroken path of analog processing between the feedback device (sensor) and control actuator (heater).

analog data. Data represented in a continuous form, as contrasted with digital data having discrete values.¹

analog output. A voltage output from an instrument that is proportional to its input. From an instrument such as a digital voltmeter, the output voltage is generated by a digital-to-analog converter so it will have a discrete number of voltage levels.

anode. The terminal that is positive with respect to the other terminal when the diode is biased in the forward direction.²



asphyxiant gas. A gas which has little or no positive toxic effect but which can bring about unconsciousness and death by displacing air and thus depriving an organism of oxygen.

autotuning. In Lake Shore Temperature Controllers, the Autotuning algorithm automatically determines the proper settings for Gain (Proportional), Reset (Integral), and Rate (Derivative) by observing the time response of the system upon changes in setpoint.

B. Symbol for magnetic flux density. See Magnetic Flux Density.

bar. Unit of pressure equal to 10^5 pascal, or 0.98697 standard atmosphere.

baud. A unit of signaling speed equal to the number of discrete conditions or signal events per second, or the reciprocal of the time of the shortest signal element in a character.²

bel (B). A dimensionless unit expressing the ration of two powers or intensities, or the ratio of a power to a reference power, such that the number of bels is the common logarithm of this ratio.¹

bifilar windings. A winding consisting of two insulated wires, side by side, with currents traveling through them in opposite directions.¹

bit. A contraction of the term "binary digit"; a unit of information represented by either a zero or a one.²

BNC. Bayonet Nut Connector.

boiling point. The temperature at which a substance in the liquid phase transforms to the gaseous phase; commonly refers to the boiling point at sea level and standard atmospheric pressure.

CalCurve Service. The service of storing a mathematical representation of a calibration curve on an EEPROM or installed in a Lake Shore instrument. Previously called a Precision Option.

calibration. To determine, by measurement or comparison with a standard, the correct (accurate) value of each scale reading on a meter or other device, or the correct value for each setting of a control knob.¹

cathode. The terminal from which forward current flows to the external circuit.²



Carbon-Glass™. A temperature sensing material fabricated from a carbon-impregnated glass matrix used to make the Lake Shore CGR family of sensors.

Caution. An operation or maintenance procedure, practice, condition, statement, etc., which, if not strictly observed, could result in damage or destruction of equipment, or loss of effectiveness.

Celsius (°C) Scale. A temperature scale that registers the freezing point of water as 0 °C and the boiling point as 100 °C under normal atmospheric pressure. Celsius degrees are purely derived units, calculated from the Kelvin Thermodynamic Scale. Formerly known as “centigrade.” See Temperature for conversions.

Cernox™. A Lake Shore resistance temperature detector based on a ceramic-oxy-nitride resistance material.

CGR. Carbon Glass Resistor.

cgs system of units. A system in which the basic units are the centimeter, gram, and second.²

Chromel™. A chromium-nickel alloy which comprises the positive lead of Type E and K thermocouples.

coercive force (coercive field). The magnetic field strength (H) required to reduce the magnetic induction (B) in a magnetic material to zero.

coercivity. generally used to designate the magnetic field strength (H) required to reduce the magnetic induction (B) in a magnetic material to zero from saturation. The coercivity would be the upper limit to the coercive force.

cold finger. A cryogenically cooled component incorporated into the dewar of an infrared detector assembly in order to maintain the sensing elements at the proper temperature (77 K or colder).

compliance voltage. See current source.

Constantan. A copper-nickel alloy which comprises the negative lead of Type E, J, and T thermocouples.

cryogen. See cryogenic fluid.¹

cryogenic. Refers to the field of low temperatures, usually –130 °F or below, as defined by 173.300(f) of Title 49 of the Code of Federal Regulations.

cryogenic fluid. A liquid that boils at temperatures of less than about 110 K at atmospheric pressure, such as hydrogen, helium, nitrogen, oxygen, air, or methane. Also known as cryogen.¹

cryostat. An apparatus used to provide low-temperature environments in which operations may be carried out under controlled conditions.¹

Curie temperature (T_c). Temperature at which a magnetized sample is completely demagnetized due to thermal agitation. Named for Pierre Curie (1859-1906), a French chemist.

current source. A type of power supply that supplies a constant current through a variable load resistance by automatically varying its compliance voltage. A single specification given as “compliance voltage” means the output current is within specification when the compliance voltage is between zero and the specified voltage.

curve. A set of data that defines the temperature response of a temperature sensor. It is used to convert the sensor's signal to temperature.

Curve 10. The voltage versus temperature characteristic followed by all DT-400 Series Silicon Diode Temperature Sensors.

decibels (dB). A unit for describing the ratio of two powers or intensities, or the ratio of a power to a reference power; equal to one-tenth bel; if P₁ and P₂ are two amounts of power, the first is said to be *n* decibels greater, where $n = 10 \log_{10}(P_1/P_2)$.¹

degree. An incremental value in the temperature scale, i.e., there are 100 degrees between the ice point and the boiling point of water in the Celsius scale and 180 degrees between the same two points in the Fahrenheit scale.

demagnetization. when a sample is exposed to an applied field (H_a), poles are induced on the surface of the sample. Some of the returned flux from these poles is inside of the sample. This returned flux tends to decrease the net magnetic field strength internal to the sample yielding a true internal field (H_{int}) given by: H_{int} = H_a – DM, where M is the volume magnetization and D is the demagnetization factor. D is dependent on the sample geometry and orientation with respect to the field.

deviation. The difference between the actual value of a controlled variable and the desired value corresponding to the setpoint.¹

Dewar. A vacuum-insulated bottle used to contain cryogenic fluid.

differential permeability. The slope of a B versus H curve: $\mu_d = dB/dH$.

differential susceptibility. The slope of a M versus H curve: $\chi_d = dM/dH$.

digital controller. A feedback control system where the feedback device (sensor) and control actuator (heater) are joined by a digital processor. In Lake Shore controllers the heater output is maintained as a variable DC current source.

digital data. Pertaining to data in the form of digits or interval quantities. Contrast with analog data.²

dimensionless sensitivity. Sensitivity of a physical quantity to a stimulus, expressed in dimensionless terms. The dimensionless temperature sensitivity of a resistance temperature sensor is expressed as $S_d = (T/R)(dR/dT)$ which is also equal to the slope of R versus T on a log-log plot, that is $S_d = d \ln R / d \ln T$. Note that the absolute temperature (in kelvin) must be used in these expressions.

DIN. Deutsches Institut für Normung.

drift, instrument. An undesired but relatively slow change in output over a period of time, with a fixed reference input. *Note:* Drift is usually expressed in percent of the maximum rated value of the variable being measured.²

DUT. Device Under Test.

electromagnet. A device in which a magnetic field is generated as the result of electrical current passing through a helical conducting coil. It can be configured as an iron-free solenoid in which the field is produced along the axis of the coil, or an iron-cored structure in which the field is produced in an air gap between pole faces. The coil can be water cooled copper or aluminum, or superconductive.

electrostatic discharge (ESD). A transfer of electrostatic charge between bodies at different electrostatic potentials caused by direct contact or induced by an electrostatic field.

error. Any discrepancy between a computed, observed, or measured quantity and the true, specified, or theoretically correct value or condition.²

excitation. Either an AC or DC input to a sensor used to produce an output signal. Common excitations include: constant current, constant voltage, or constant power.

Fahrenheit (°F) Scale. A temperature scale that registers the freezing point of water as 32 °F and the boiling point as 212 °F under normal atmospheric pressure. *See* Temperature for conversions.

fanout board. A fanout board is a printed circuit board which is used to interconnect the Device-Under-Test (DUT) to the coax signal lines (via the interface board) in the MTD System. The socket for a particular device package is mounted on the fanout board and the contacts of the socket are soldered to the board traces. The 50 Ω stripline transmission traces on the fanout board are gold plated to enhance the electrical connections and to inhibit corrosion.

feedthrough. Provides leak-proof (hermetic) access from one volume to another without breaking the integrity of either space. In Lake Shore equipment, a feedthrough is used to provide wiring from the room temperature environment to the cryogenic environment inside a dewar.

four-lead. measurement technique where one pair of excitation leads and an independent pair of measurement leads are used to measure a sensor. This method reduces the effect of lead resistance on the measurement.

FPA. Focal Plane Array.

GaAIAs. Gallium-aluminum-arsenide semiconducting material used to make the special Lake Shore TG family of diode temperature sensors.

gamma. A cgs unit of low-level flux density, where 100,000 gamma equals one oersted, or 1 gamma equals 10^{-5} oersted.

gauss (G). The cgs unit for magnetic flux density (B). 1 gauss = 10^{-4} tesla. Named for Karl Fredrich Gauss (1777–1855) a German mathematician, astronomer, and physicist.

gaussian system (units). A system in which centimeter-gram-second units are used for electric and magnetic qualities.

general purpose interface bus (GPIB). Another term for the IEEE-488 bus.

germanium (Ge). A common temperature sensing material fabricated from doped germanium to make the Lake Shore GR family of resistance temperature sensor elements.

gilbert (Gb). A cgs electromagnetic unit of the magnetomotive force required to produce one maxwell of magnetic flux in a magnetic circuit of unit reluctance. One gilbert is equal to $10/4\pi$ ampere-turn. Named for William Gilbert (1540–1603), an English physicist; hypothesized that the earth is a magnet.

gilbert per centimeter. Practical cgs unit of magnet intensity. Gilberts per cm are the same as oersteds.

Greek alphabet. The Greek alphabet is defined as follows:

Alpha	α	A	Iota	ι	I	Rho	ρ	P
Beta	β	B	Kappa	κ	K	Sigma	σ	Σ
Gamma	γ	Γ	Lambda	λ	Λ	Tau	τ	T
Delta	δ	Δ	Mu	μ	M	Upsilon	υ	Υ
Epsilon	ε	E	Nu	ν	N	Phi	φ	Φ
Zeta	ζ	Z	Xi	ξ	Ξ	Chi	χ	X
Eta	η	H	Omicron	ο	O	Psi	ψ	Ψ
Theta	θ	Θ	Pi	π	Π	Omega	ω	Ω

ground. A conducting connection, whether intentional or accidental, by which an electric circuit or equipment is connected to the earth, or to some conducting body of relatively large extent that serves in place of the earth.
Note: It is used for establishing and maintaining the potential of the earth (or of the conducting body) or approximately that potential, on conductors connected to it, and for conducting ground current to and from the earth (or of the conducting body).²

H. Symbol for magnetic field strength. See Magnetic Field Strength.

Hall effect. The generation of an electric potential perpendicular to both an electric current flowing along a thin conducting material and an external magnetic field applied at right angles to the current. Named for Edwin H. Hall (1855–1938), an American physicist.

hazard communication standard (HCS). The OSHA standard cited in 29 CFR 1910.1200 requiring communication of risks from hazardous substances to workers in regulated facilities.

hertz (Hz). A unit of frequency equal to one cycle per second.

hysteresis. The dependence of the state of a system on its previous history, generally in the form of a lagging of a physical effect behind its cause.¹ Also see magnetic hysteresis.

I.D. Inner diameter.

IEC. International Electrotechnical Commission.

IEEE. Institute of Electrical and Electronics Engineers.

IEEE-488. An instrumentation bus with hardware and programming standards designed to simplify instrument interfacing. The addressable, parallel bus specification is defined by the IEEE.

initial permeability. The permeability determined at $H = 0$ and $B = 0$.

initial susceptibility. The susceptibility determined at $H = 0$ and $M = 0$.

infrared (IR). For practical purposes any radiant energy within the wavelength range 770 to 10^6 nanometers is considered infrared energy.² The full range is usually divided into three sub-ranges: near IR, far IR, and sub-millimeter.

input card. Electronics on a printed circuit board (card) that plug into an instrument main frame. Used by configurable instruments to allow for different sensor types or interface options.

interchangeability. Ability to exchange one sensor or device with another of the same type without a significant change in output or response.

international system of units (SI). A universal coherent system of units in which the following seven units are considered basic: meter, kilogram, second, ampere, kelvin, mole, and candela. The International System of Units, or *Système International d'Unités* (SI), was promulgated in 1960 by the Eleventh General Conference on Weights and Measures. For definition, spelling, and protocols, see Reference 3 for a short, convenient guide.

interpolation table. A table listing the output and sensitivity of a sensor at regular or defined points which may be different from the points at which calibration data was taken.

intrinsic coercivity. The magnetic field strength (H) required to reduce the magnetization (M) or intrinsic induction in a magnetic material to zero.

intrinsic induction. The contribution of the magnetic material (B_i) to the total magnetic induction (B).

$$B_i = B - \mu_0 H \quad (\text{SI}) \qquad B_i = B - H \quad (\text{cgs})$$

IPTS-68. International Practical Temperature Scale of 1968. Also abbreviated as T_{68} .

isolated (neutral system). A system that has no intentional connection to ground except through indicating, measuring, or protective devices of very-high impedance.²

ITS-90. International Temperature Scale of 1990. Also abbreviated as T_{90} . This scale was designed to bring into as close a coincidence with thermodynamic temperatures as the best estimates in 1989 allowed.

Kelvin (K). The unit of temperature on the Kelvin Scale. It is one of the base units of SI. The word "degree" and its symbol (°) are omitted from this unit. See Temperature Scale for conversions.

Kelvin Scale. The Kelvin Thermodynamic Temperature Scale is the basis for all international scales, including the ITS-90. It is fixed at two points: the absolute zero of temperature (0 K), and the triple point of water (273.16 K), the equilibrium temperature that pure water reaches in the presence of ice and its own vapor.

LCC. Leadless Chip Carrier.

line regulation. The maximum steady-state amount that the output voltage or current will change as the result of a specified change in input line voltage (usually for a step change between 105–125 or 210–250 volts, unless otherwise specified).

line voltage. The RMS voltage of the primary power source to an instrument.

liquid helium (LHe). Used for low temperature and superconductivity research: minimum purity 99.998%. Boiling point at 1 atm = 4.2 K. Latent heat of vaporization = 2.6 kilojoules per liter. Liquid density = 0.125 kilograms per liter.

EPA Hazard Categories: Immediate (Acute)
Health and Sudden Release of Pressure Hazards
DOT Name: Helium, Refrigerated Liquid

DOT Label: Nonflammable Gas
DOT Class: Nonflammable Gas
DOT ID No: UN 1963

liquid nitrogen (LN₂). Also used for low temperature and superconductivity research and for its refrigeration properties such as in freezing tissue cultures: minimum purity 99.998%, O₂ 8 ppm max. Boiling point at 1 atm = 77.4 K. Latent heat of vaporization = 160 kilojoules per liter. Liquid density = 0.81 kilograms per liter.

EPA Hazard Categories: Immediate (Acute)
Health and Sudden Release of Pressure Hazards
DOT Name: Nitrogen, Refrigerated Liquid

DOT Label: Nonflammable Gas
DOT Class: Nonflammable Gas
DOT ID No: UN 1977

load regulation. A steady-state decrease of the value of the specified variable resulting from a specified increase in load, generally from no-load to full-load unless otherwise specified.

LSCI. Lake Shore Cryotronics, Inc.

M. Symbol for magnetization. See magnetization.

magnetic air gap. The air space, or non-magnetic portion, of a magnetic circuit.

magnetic field strength (H). The magnetizing force generated by currents and magnetic poles. For most applications, the magnetic field strength can be thought of as the applied field generated, for example, by a superconducting magnet. The magnetic field strength is not a property of materials. Measure in SI units of A/m or cgs units of oersted.

magnetic flux density (B). Also referred to as magnetic induction. This is the net magnetic response of a medium to an applied field, H. The relationship is given by the following equation: $B = \mu_0 (H + M)$ for SI, and $B = H + 4\pi M$ for cgs, where H = magnetic field strength, M = magnetization, and μ_0 = permeability of free space = $4\pi \times 10^{-7}$ H/m.

magnetic hysteresis. The property of a magnetic material where the magnetic induction (B) for a given magnetic field strength (H) depends upon the past history of the samples magnetization.

magnetic induction (B). See magnetic flux density.

magnetic moment (m). This is the fundamental magnetic property measured with dc magnetic measurements systems such as a vibrating sample magnetometer, extraction magnetometer, SQUID magnetometer, etc. The exact technical definition relates to the torque exerted on a magnetized sample when placed in a magnetic field. Note that the moment is a total attribute of a sample and alone does not necessarily supply sufficient information in understanding material properties. A small highly magnetic sample can have exactly the same moment as a larger weakly magnetic sample (see Magnetization). Measured in SI units as $A \cdot m^2$ and in cgs units as emu. $1 \text{ emu} = 10^{-3} A \cdot m^2$.

magnetic units. Units used in measuring magnetic quantities. Includes ampere-turn, gauss, gilbert, line of force, maxwell, oersted, and unit magnetic pole.

magnetization (M). This is a material specific property defined as the magnetic moment (m) per unit volume (V). $M = m/V$. Measured in SI units as A/m and in cgs units as emu/cm^3 . $1 \text{ emu/cm}^3 = 10^3 \text{ A/m}$. Since the mass of a sample is generally much easier to determine than the volume, magnetization is often alternately expressed as a mass magnetization defined as the moment per unit mass.

mains. See line voltage.

material safety data sheet (MSDS). OSHA Form 20 contains descriptive information on hazardous chemicals under OSHA's Hazard Communication Standard (HCS). These data sheets also provide precautionary information on the safe handling of the gas as well as emergency and first aid procedures.

microcontroller. A microcomputer, microprocessor, or other equipment used for precise process control in data handling, communication, and manufacturing.¹

MKSA System of Units. A system in which the basic units are the meter, kilogram, and second, and the ampere is a derived unit defined by assigning the magnitude $4\pi \times 10^{-7}$ to the rationalized magnetic constant (sometimes called the permeability of space).

MTD. Modular Test Dewar.

NBS. National Bureau of Standards. Now referred to as NIST.

NbTi. Niobium-titanium. A superconductive alloy with a transition temperature typically near 9 K in zero magnetic field.

negative temperature coefficient (NTC). Refers to the sign of the temperature sensitivity. For example, the resistance of a NTC sensor decreases with increasing temperature.

National Institute of Standards and Technology (NIST). Government agency located in Gaithersburg, Maryland and Boulder, Colorado, that defines measurement standards in the United States.

noise (electrical). Unwanted electrical signals that produce undesirable effects in circuits of control systems in which they occur.²

normalized sensitivity. For resistors, signal sensitivity (dR/dT) is geometry dependent; i.e., dR/dT scales directly with R; consequently, very often this sensitivity is normalized by dividing by the measured resistance to give a sensitivity, s_T , in percent change per kelvin. $s_T = (100/R) (dR/dT) \%K$, where T is temperature in kelvin and R is resistance in ohms.

normally closed (N.C.). A term used for switches and relay contacts. Provides a closed circuit when actuator is in the free (unenergized) position.

normally open (N.O.). A term used for switches and relay contacts. Provides an open circuit when actuator is in the free (unenergized) position.

Note. An operation or maintenance procedure, practice, condition, statement, etc., which is essential to emphasize. Multiple warnings, cautions, or notes will be prefaced with bullets.

O.D. Outer diameter.

oersted (Oe). The cgs unit for the magnetic field strength (H). 1 oersted = $10^3/4\pi$ ampere/meter \approx 79.58 ampere/meter.

ohm (Ω). The SI unit of resistance (and of impedance). The ohm is the resistance of a conductor such that a constant current of one ampere in it produces a voltage of one volt between its ends.²

pascal (Pa). The SI unit of pressure equal to 1 N/m². Equal to 1.45×10^{-4} psi, 1.0197×10^{-5} kgf/cm², 7.5×10^{-3} torr, 4.191×10^{-3} inches of water, or 1×10^{-5} bar.

permeability. Material parameter which is the ratio of the magnetic induction (B) to the magnetic field strength (H): $\mu = B/H$. Also see Initial Permeability and Differential Permeability.

platinum (Pt). A common temperature sensing material fabricated from pure platinum to make the Lake Shore PT family of resistance temperature sensor elements.

polynomial fit. A mathematical equation used to fit calibration data. Polynomials are constructed of finite sums of terms of the form $a_i x_i$, where a_i is the i^{th} fit coefficient and x_i is some function of the dependent variable.

pop-off. Another term for relief valve.

positive temperature coefficient (PTC). Refers to the sign of the temperature sensitivity. For example, the resistance of a PTC sensor increases with increasing temperature.

pounds per square inch (psi). A unit of pressure. 1 psi = 6.89473 kPa. Variations include psi absolute (psia) measured relative to vacuum (zero pressure) where one atmosphere pressure equals 14.696 psia and psi gauge (psig) where gauge measured relative to atmospheric or some other reference pressure.

ppm. Parts per million, e.g., 4×10^{-6} is four parts per million.

precision. Careful measurement under controlled conditions which can be repeated with similar results. See repeatability. Also means that small differences can be detected and measured with confidence. See resolution.

prefixes. SI prefixes used throughout this manual are as follows:

Factor	Prefix	Symbol	Factor	Prefix	Symbol
10^{24}	yotta	Y	10^{-1}	deci	d
10^{21}	zetta	Z	10^{-2}	centi	c
10^{18}	exa	E	10^{-3}	milli	m
10^{15}	peta	P	10^{-6}	micro	μ
10^{12}	tera	T	10^{-9}	nano	n
10^9	giga	G	10^{-12}	pico	p
10^6	mega	M	10^{-15}	femto	f
10^3	kilo	k	10^{-18}	atto	a
10^2	hecto	h	10^{-21}	zepto	z
10^1	deka	da	10^{-24}	yocto	y

probe. A long, thin body containing a sensing element which can be inserted into a system in order to make measurements. Typically, the measurement is localized to the region near the tip of the probe.

proportional, integral, derivative (PID). A control function where output is related to the error signal in three ways. Proportional (gain) acts on the instantaneous error as a multiplier. Integral (reset) acts on the area of error with respect to time and can eliminate control offset or droop. Derivative (rate) acts on the rate of change in error to dampen the system, reducing overshoot.

quench. A condition where the superconducting magnet goes "normal," i.e., becomes non-superconductive. When this happens, the magnet becomes resistive, heat is generated, liquid Helium is boiled off, and the Magnet Power Supply will shut down due to the sudden increase in current demand.

rack mount. An instrument is rack mountable when it has permanent or detachable brackets that will allow it to be securely mounted in a 19-inch instrument rack. A full rack instrument requires the entire width of the rack. Two half rack instruments will fit horizontally in a rack width.

relief valve. A type of pressure relief device which is designed to relieve excessive pressure, and to reclose and reseal to prevent further flow of gas from the cylinder after reseating pressure has been achieved.

remanence. The remaining magnetic induction in a magnetic material when the material is first saturated and then the applied field is reduced to zero. The remanence would be the upper limit to values for the remanent induction. Note that no strict convention exists for the use of remanent induction and remanence and in some contexts the two terms may be used interchangeably.

remanent induction. The remaining magnetic induction in a magnetic material after an applied field is reduced to zero. Also see remanence.

repeatability. The closeness of agreement among repeated measurements of the same variable under the same conditions.²

resistance temperature detector (RTD). Resistive sensors whose electrical resistance is a known function of the temperature, made of, e.g., carbon-glass, germanium, platinum, or rhodium-iron.

resolution. The degree to which nearly equal values of a quantity can be discriminated.²

display resolution. The resolution of an instrument's physical display. This is not always the same as the measurement resolution of the instrument. Decimal display resolution specified as "*n* digits" has 10^n possible display values. A resolution of *n* and one-half digits has 2×10^n possible values.

measurement resolution. The ability of an instrument to resolve a measured quantity. For digital instrumentation this is often defined by the analog to digital converter being used. A *n*-bit converter can resolve one part in 2^n . The smallest signal change that can be measured is the full scale input divided by 2^n for any given range. Resolution should not be confused with accuracy.

RhFe. Rhodium-iron. Rhodium alloyed with less than one atomic percent iron is used to make the Lake Shore RF family of sensors. Rhodium-iron is a spin fluctuation alloy which has a significant temperature coefficient of resistance below 20 K where most metals rapidly lose sensitivity.

RJ-11. A modular connector with 6 conductors commonly used with telephones.

Roman numerals. Letters employed in the ancient Roman system of numeration as follows:

I	1	VI	6	L	50
II	2	VII	7	C	100
III	3	VIII	8	D	500
IV	4	IX	9	M	1000
V	5	X	10		

root mean square (RMS). The square root of the time average of the square of a quantity; for a periodic quantity the average is taken over one complete cycle. Also known as effective value.¹

room temperature compensation. Thermocouples are a differential measurement device. Their signal represents the difference in temperature between their ends. An ice bath is often used to reference the measurement end to 0 °C so most curves are normalized to that temperature. Room temperature compensation replaces an ice bath by monitoring the temperature of the thermocouple's terminals and normalizing the reading mathematically.

RS-232C. Bi-directional computer serial interface standard defined by the Electronic Industries Association (EIA). The interface is single-ended and non-addressable.

Seebeck effect. The development of a voltage due to differences in temperature between two junctions of dissimilar metals in the same circuit.¹

self-heating. Heating of a device due to dissipation of power resulting from the excitation applied to the device. The output signal from a sensor increases with excitation level, but so does the self-heating and the associated temperature measurement error.

sensitivity. The ratio of the response or change induced in the output to a stimulus or change in the input. Temperature sensitivity of a resistance temperature detector is expressed as $S = dR/dT$.

setpoint. The value selected to be maintained by an automatic controller.¹

serial interface. A computer interface where information is transferred one bit at a time rather than one byte (character) at a time as in a parallel interface. RS-232C is the most common serial interface.

SI. Système International d'Unités. See International System of Units.

silicon diode. Temperature sensor based on the forward voltage drop at constant current through a pn semiconductor junction formed in crystalline silicon.

SoftCal™. In Lake Shore instruments, SoftCal™ is used to improve the accuracy of a DT-400 Series Silicon Temperature Diode Sensor. This reduces the error between the sensor and the Standard Curve 10 used by the instrument to convert input voltage from the diode to a corresponding temperature.

stability. The ability of an instrument or sensor to maintain a constant output given a constant input.

strain relief. A predetermined amount of slack to relieve tension in component or lead wires. Also called stress relief.

superconducting magnet. An electromagnet whose coils are made of a type II superconductor with a high transition temperature and extremely high critical field, such as niobium-tin, Nb₃Sn; it is capable of generating magnetic fields of 100,000 oersteds and more with no steady power dissipation.¹ See electromagnet.

susceptance. In electrical terms, susceptance is defined as the reciprocal of reactance and the imaginary part of the complex representation of admittance: [suscept(ibility) + (conduct)ance].

susceptibility (χ). Parameter giving an indication of the response of a material to an applied magnetic field. The susceptibility is the ratio of the magnetization (M) to the applied field (H). $\chi = M/H$. In both SI units and cgs units the volume susceptibility is a dimensionless parameter. Multiply the cgs susceptibility by 4π to yield the SI susceptibility. See also Initial Susceptibility and Differential Susceptibility. As in the case of magnetization, the susceptibility is often seen expressed as a mass susceptibility or a molar susceptibility depending upon how M is expressed.

temperature scales. See Kelvin Scale, Celsius Scale, and ITS-90. Proper metric usage requires that only kelvin and degrees Celsius be used. However, since degrees Fahrenheit is in such common use, all three scales are delineated as follows:

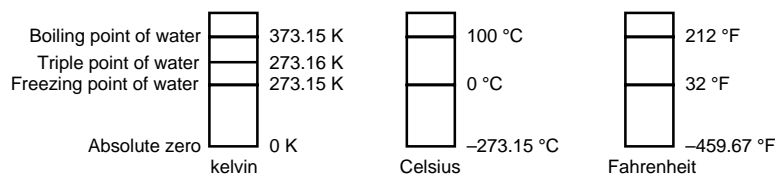

To convert kelvin to Celsius, subtract 273.15.

To convert Celsius to Fahrenheit: multiply °C by 1.8 then add 32, or: $^{\circ}\text{F} = (1.8 \times ^{\circ}\text{C}) + 32$.

To convert Fahrenheit to Celsius: subtract 32 from °F then divide by 1.8, or: $^{\circ}\text{C} = (^{\circ}\text{F} - 32) / 1.8$.

temperature coefficient, measurement. The measurement accuracy of an instrument is affected by changes in ambient temperature. The error is specified as an amount of change (usually in percent) for every one degree change in ambient temperature.

tesla (T). The SI unit for magnetic flux density (B). 1 tesla = 10^4 gauss

thermal emf. An electromotive force arising from a difference in temperature at two points along a circuit, as in the Seebeck effect.¹

thermocouple. A pair of dissimilar conductors so joined at two points that an electromotive force is developed by the thermoelectric effects when the junctions are at different temperatures.²

thixotropy. Property of certain gels which liquefy when subjected to vibratory forces, such as ultrasonic waves or even simple shaking, and then solidify again when left standing.¹

tolerance. The range between allowable maximum and minimum values.

torr. Unit of pressure. 1 torr \approx 1 mm of mercury. 1 atmosphere = 760 torr.

two-lead. Measurement technique where one pair of leads is used for both excitation and measurement of a sensor. This method will not reduce the effect of lead resistance on the measurement.

unit magnetic pole. A pole with a strength such that when it is placed 1 cm away from a like pole, the force between the two is 1 dyne.

volt (V). The difference of electric potential between two points of a conductor carrying a constant current of one ampere, when the power dissipated between these points is equal to one watt.²

volt-ampere (VA). The SI unit of apparent power. The volt-ampere is the apparent power at the points of entry of a single-phase, two-wire system when the product of the RMS value in amperes of the current by the RMS value in volts of the voltage is equal to one.²

watt (W). The SI unit of power. The watt is the power required to do work at the rate of 1 joule per second.²

Warning. An operation or maintenance procedure, practice, condition, statement, etc., which, if not strictly observed, could result in injury, death, or long-term health hazards to personnel.

References:

- 1 Sybil P. Parker, Editor. *Dictionary of Scientific and Technical Terms: Third Edition*. New York: McGraw Hill, 1969 (ISBN 0-395-20360-0)
- 2 Christopher J. Booth, Editor. *The New IEEE Standard Dictionary of Electrical and Electronic Terms: IEEE Std 100-1992, Fifth Edition*. New York: Institute of Electrical and Electronics Engineers, 1993 (ISBN 1-55937-240-0). Definitions printed with permission of the IEEE.
- 3 Nelson, Robert A. *Guide For Metric Practice*, Page BG7 - 8, Physics Today, Eleventh Annual Buyer's Guide, August 1994 (ISSN 0031-9228 coden PHTOAD)

APPENDIX B

UNITS FOR MAGNETIC PROPERTIES

Table B-1. Conversion from CGS to SI Units

Quantity	Symbol	Gaussian & CGS emu ^a	Conversion Factor, C ^b	SI & Rationalized mks ^c
Magnetic flux density, Magnetic induction	B	gauss (G) ^d	10 ⁻⁴	tesla (T), Wb/m ²
Magnetic Flux	φ	maxwell (Mx), G·cm ²	10 ⁻⁸	weber (Wb), volt second (V·s)
Magnetic potential difference, magnetomotive force	U, F	gilbert (Gb)	10/4π	ampere (A)
Magnetic field strength, magnetizing force	H	oersted (Oe), ^e Gb/cm	10 ³ /4π	A/m ^f
(Volume) magnetization ^g	M	emu/cm ^{3h}	10 ³	A/m
(Volume) magnetization	4πM	G	10 ³ /4π	A/m
Magnetic polarization, intensity of magnetization	J, I	emu/cm ³	4π × 10 ⁻⁴	T, Wb/m ²ⁱ
(Mass) magnetization	σ, M	emu/g	$\frac{1}{4\pi \times 10^{-7}}$	A·m ² /kg Wb·m/kg
Magnetic moment	m	emu, erg/G	10 ⁻³	A·m ² , joule per tesla (J/T)
Magnetic dipole moment	j	emu, erg/G	4π × 10 ⁻¹⁰	Wb·m ¹
(Volume) susceptibility	χ, κ	dimensionless emu/cm ³	(4π) ⁻² × 10 ⁻⁷	Henry per meter (H/m), Wb/(A·m)
(Mass) susceptibility	χ _p , κ _p	cm ³ /g, emu/g	$\frac{4\pi \times 10^{-3}}{(4\pi)^2 \times 10^{-10}}$	m ³ /kg H·m ² /kg
(Molar) susceptibility	χ _{mol} , κ _{mol}	cm ³ /mol, emu/mol	$\frac{4\pi \times 10^{-6}}{(4\pi)^2 \times 10^{-13}}$	m ³ /mol H·m ² /mol
Permeability	μ	dimensionless	4π × 10 ⁻⁷	H/m, Wb/(A·m)
Relative permeability ^j	μ _r	not defined	-	dimensionless
(Volume) energy density, energy product ^k	W	erg/cm ³	10 ⁻¹	J/m ³
Demagnetization factor	D, N	dimensionless	1/4π	dimensionless

NOTES:

- a. Gaussian units and cgs emu are the same for magnetic properties. The defining relation is $B = H + 4\pi M$.
- b. Multiply a number in Gaussian units by C to convert it to SI (e.g. $1 \text{ G} \times 10^{-4} \text{ T/G} = 10^{-4} \text{ T}$).
- c. SI (Système International d'Unités) has been adopted by the National Bureau of Standards. Where two conversion factors are given, the upper one is recognized under, or consistent with, SI and is based on the definition $B = \mu_0(H + M)$, where $\mu_0 = 4\pi \times 10^{-7} \text{ H/m}$. The lower one is not recognized under SI and is based on the definition $B = \mu_0 H + J$, where the symbol I is often used in place of J.
- d. $1 \text{ gauss} = 10^9 \text{ gamma } (\gamma)$.
- e. Both oersted and gauss are expressed as $\text{cm}^{-3/2} \cdot \text{g}^{1/2} \cdot \text{s}^{-1}$ in terms of base units.
- f. A/m was often expressed as "ampere-turn per meter" when used for magnetic field strength.
- g. Magnetic moment per unit volume.
- h. The designation "emu" is not a unit.
- i. Recognized under SI, even though based on the definition $B = \mu_0 H + J$. See footnote c.
- j. $\mu_r = \mu/\mu_0 = 1 + \chi$, all in SI. μ_r is equal to Gaussian μ .
- k. $B \cdot H$ and $\mu_0 M \cdot H$ have SI units J/m^3 , $\text{M} \cdot \text{H}$ and $B \cdot H/4\pi$ have Gaussian units erg/cm^3 .

R.B. Goldfarb and F.R. Fickett, U.S. Department of Commerce, National Bureau of Standards, Boulder, Colorado 80303, March 1985, NBS Special Publication 696. For sale by the Superintendent of Documents, U.S. Government Printing Office, Washington, D.C. 20402.

Table B-2. Recommended SI Values for Physical Constants

Quantity	Symbol	Value (SI units)
Permeability of Vacuum	μ_0	$4\pi \times 10^{-7} \text{ H m}^{-1}$
Speed of Light in Vacuum	c	$2.9979 \times 10^8 \text{ m s}^{-1}$
Permittivity of Vacuum	$\epsilon_0 = (\mu_0 c^2)^{-1}$	$8.8542 \times 10^{-12} \text{ F m}^{-1}$
Fine Structure Constant, $\mu_0 e^2 / 2h$	$\frac{\alpha}{\alpha^{-1}}$	0.0073 137.0360
Elementary Charge	e	$1.6022 \times 10^{-19} \text{ C}$
Planck's Constant	h $h = h/2\pi$	$6.6262 \times 10^{-34} \text{ J Hz}^{-1}$ $1.0546 \times 10^{-34} \text{ J s}$
Avogadro's Constant	N_A	$6.0220 \times 10^{23} \text{ mol}^{-1}$
Atomic Mass Unit	$1u = (10^{-3} \text{ kg mol}^{-1}/N_A$	$1.6605 \times 10^{-27} \text{ kg}$
Electron Rest Mass	m_e	$0.9109 \times 10^{-30} \text{ kg}$ $5.4858 \times 10^{-4} \text{ u}$
Proton Rest Mass	m_p	$1.6726 \times 10^{-27} \text{ kg}$ 1.0073 u
Neutron Rest Mass	m_n	$1.6749 \times 10^{-27} \text{ kg}$ 1.0087 u
Magnetic Flux Quantum	$\phi = h/2e$ h/e	$2.0679 \times 10^{-15} \text{ Wb}$ $4.1357 \times 10^{-15} \text{ J Hz}^{-1} \text{ C}^{-1}$
Josephson Frequency-Voltage Ratio	$2e/h$	$483.5939 \text{ THz V}^{-1}$
Quantum of Circulation	$h/2m_e$ h/m_e	$3.6369 \times 10^{-4} \text{ J Hz}^{-1} \text{ kg}^{-1}$ $7.2739 \times 10^{-4} \text{ J Hz}^{-1} \text{ C}^{-1}$
Rydberg Constant	R_∞	$1.0974 \times 10^7 \text{ m}^{-1}$
Proton Moment in Nuclear Magnetons	μ_p/μ_N	2.7928
Bohr Magneton	$\mu_B = eh/2m_e$	$9.2741 \times 10^{-24} \text{ J T}^{-1}$
Proton Gyromagnetic Ratio	γ_p	$2.6752 \times 10^8 \text{ s}^{-1} \text{ T}^{-1}$
Diamagnetic Shielding Factor, Spherical H ₂ O Sample	$1 + \sigma(\text{H}_2\text{O})$	1.0000
Molar Mass Constant	R	$8.3144 \text{ J mol}^{-1} \text{ K}^{-1}$
Molar Volume, Ideal Gas ($T_0 = 273.15\text{K}$, $p_0 = 1 \text{ atm}$)	$V_m = RT_0/p_0$	$0,0224 \text{ m}^3 \text{ mol}^{-1}$
Boltzman Constant	$k = R/N_A$	$1.3807 \times 10^{-23} \text{ J K}^{-1}$
Stefan-Boltzman Constant	$\sigma = (\pi^2/60) k^4/h^3 c^2$	$5.6703 \times 10^{-8} \text{ W m}^{-2} \text{ K}^{-4}$
First Radiation Constant	$c_1 = 2\pi hc^2$	$3.7418 \times 10^{-16} \text{ W m}^{-2}$
Second Radiation Constant	$c_2 = hc/k$	0.0144 mK
Gravitation Constant	G	$6.6720 \times 10^{-11} \text{ N m}^2 \text{ kg}^{-2}$

Data (abbreviated to 4 decimal places) from CODATA Bulletin No. 11, ICSU CODATA Central Office, 19 Westendstrasse, 6 Frankfurt/Main, Germany. Copies of this bulletin are available from this office.

APPENDIX C

TEMPERATURE SCALES

C1.0 DEFINITION

Temperature is a fundamental unit of measurement which describes the kinetic and potential energies of the atoms and molecules of bodies. When the energies and velocities of the molecules in a body are increased, the temperature is increased whether the body is a solid, liquid, or gas. Thermometers are used to measure temperature. The temperature scale is based on the temperature at which ice, liquid water, and water vapor are all in equilibrium. This temperature is called the triple point of water and is assigned the value 0 °C, 32 °F, and 273.15 K. These three temperature scales are defined as follows:

Celsius. Abbreviation: °C. A temperature scale that registers the freezing point of water as 0 °C and the boiling point as 100 °C under normal atmospheric pressure. Formerly known as “Centigrade.” Originally devised by Anders Celsius (1701–1744), a Swedish astronomer.

Fahrenheit. Abbreviation: °F. A temperature scale that registers the freezing point of water as 32 °F and the boiling point as 212 °F under normal atmospheric pressure. Originally devised by Gabriel Fahrenheit (1686–1736), a German physicist residing in Holland; developed use of mercury in thermometry.

Kelvin. Abbreviation: K. An absolute scale of temperature, the zero point of which is approximately –273.15°C. Scale units are equal in magnitude to Celsius degrees. Originally devised by Lord Kelvin, William Thompson, (1824–1907), a British physicist, mathematician, and inventor.

C2.0 COMPARISON

The three temperature scales are graphically compared in Figure C-1.

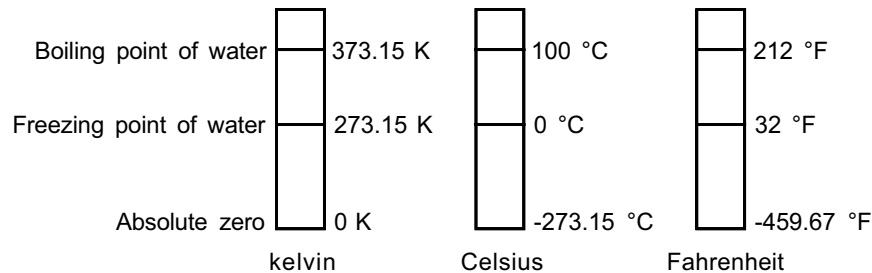

Figure C-1. Temperature Scale Comparison

C3.0 CONVERSIONS

To convert Fahrenheit to Celsius: subtract 32 from °F then divide by 1.8, or:

$$^{\circ}\text{C} = (^{\circ}\text{F} - 32) \div 1.8$$

To convert Celsius to Fahrenheit: multiply °C by 1.8 then add 32, or:

$$^{\circ}\text{F} = (1.8 \times ^{\circ}\text{C}) + 32$$

To convert Fahrenheit to kelvin, first convert °F to °C, then add 273.

To convert Celsius to kelvin, add 273.

Table C-1. Temperature Conversion Table

°F	°C	K	°F	°C	K	°F	°C	K
-459.67	-273.15	0	-292	-180	93.15	-129.67	-89.82	183.33
-454	-270	3.15	-290	-178.89	94.26	-120	-84.44	188.71
-450	-267.78	5.37	-289.67	-178.71	94.44	-119.67	-84.26	188.89
-449.67	-267.59	5.56	-280	-173.33	99.82	-117.67	-83.15	190
-441.67	-263.15	10	-279.67	-173.15	100	-112	-80	193.15
-440	-262.22	10.93	-274	-170	103.15	-110	-78.89	194.26
-439.67	-262.04	11.11	-270	-167.78	105.57	-109.67	-78.71	194.44
-436	-260	13.15	-269.67	-167.59	105.56	-100	-73.33	199.82
-430	-256.67	16.48	-261.67	-163.15	110	-99.67	-73.15	200
-429.67	-256.48	16.67	-260	-162.22	110.93	-94	-70	203.15
-423.67	-253.15	20	-259.67	-162.04	111.11	-90	-67.78	205.37
-420	-251.11	22.04	-256	-160	113.15	-89.67	-67.59	205.56
-419.67	-250.93	22.22	-250	-156.67	116.48	-81.67	-63.15	210
-418.00	-250	23.15	-249.67	-156.48	116.67	-80	-62.22	210.93
-410	-245.56	27.59	-243.67	-153.15	120	-79.67	-62.04	211.11
-409.67	-245.37	27.78	-240	-151.11	122.04	-76	-60	213.15
-405.67	-243.15	30	-239.67	-150.93	122.22	-70	-56.67	216.48
-400	-240	33.15	-238	-150	123.15	-69.67	-56.48	216.67
-399.67	-239.82	33.33	-230	-145.56	127.59	-63.67	-53.15	220
-390	-234.44	38.71	-229.67	-145.37	127.78	-60	-51.11	222.04
-389.67	-234.26	38.89	-225.67	-143.15	130	-59.67	-50.93	222.22
-387.67	-233.15	40	-220	-140	133.15	-58	-50	223.15
-382	-230	43.15	-219.67	-139.82	133.33	-50	-45.56	227.59
-380	-228.89	44.26	-210	-134.44	138.71	-49.67	-45.37	227.78
-379.67	-228.71	44.44	-209.67	-134.26	138.89	-45.67	-43.15	230
-370	-223.33	49.82	-207.67	-133.15	140	-40	-40	233.15
369.67	-223.15	50	-202	-130	143.15	-39.67	-39.82	233.33
-364	-220	53.15	-200	-128.89	144.26	-30	-34.44	238.71
-360	-217.78	55.37	-199.67	-128.71	144.44	-29.67	-34.26	238.89
-359.67	-217.59	55.56	-190	-123.33	149.82	-27.67	-33.15	240
-351.67	-213.15	60	189.67	-123.15	150	-22	-30	243.15
-350	-212.22	60.93	-184	-120	153.15	-20	-28.89	244.26
-349.67	-212.04	61.11	-180	-117.78	155.37	-19.67	-28.71	244.44
-346	-210	63.15	-179.67	-117.59	155.56	-10	-23.33	249.82
-340	-206.67	66.48	-171.67	-113.15	160	-9.67	-23.15	250
-339.67	-206.48	66.67	-170	-112.22	160.93	-4	-20	253.15
-333.67	-203.15	70	-169.67	-112.04	161.11	0	-17.78	255.37
-330	-201.11	72.04	-166	-110	163.15	+0.33	-17.59	255.56
-329.67	-200.93	72.22	-160	-106.67	166.48	8.33	-13.15	260
-328	-200	73.15	-159.67	-106.48	166.67	10	-12.22	260.93
-320	-195.56	77.59	-153.67	103.15	170	10.33	-12.04	261.11
-319.67	-195.37	77.78	-150	-101.11	172.04	14	-10	263.15
-315.67	-193.15	80	-149.67	-100.93	172.22	20	-6.67	266.48
-310	-190	83.15	-148	-100	173.15	20.33	-6.48	266.67
-309.67	-189.82	83.33	-140	-95.96	177.59	26.33	-3.15	270
-300	-184.44	88.71	-139.67	-95.37	177.78	30	-1.11	272.04
-299.67	-184.26	88.89	-135.67	-93.15	180	30.33	-0.93	272.22
-297.67	-183.15	90	-130	-90	183.15	32	0	273.15

APPENDIX D

TABLE OF ELEMENTS

Element	Symbol	Atomic Number ¹	Atomic Weight	Element	Symbol	Atomic Number ¹	Atomic Weight
Actinium	Ac	89	227.0278	Mercury	Hg	80	200.59
Aluminum	Al	13	26.98154	Molybdenum	Mo	42	95.94
Americium	Am	95	(243)	Neodymium	Nd	60	144.24
Antimony	Sb	51	121.75	Neon	Ne	10	20.179
Argon	Ar	18	39.948	Neptunium	Np	93	237.0482
Arsenic	As	33	74.9216	Nickel	Ni	28	58.69
Astatine	At	85	(210)	Niobium	Nb	41	92.9064
Barium	Ba	56	137.33	Nitrogen	N	7	14.0067
Berkelium	Bk	97	(247)	Nobelium	No	102	(259)
Beryllium	Be	4	9.01218	Osmium	Os	76	190.2
Bismuth	Bi	83	208.9804	Oxygen	O	8	15.9994
Boron	B	5	10.81	Palladium	Pd	46	106.42
Bromine	Br	35	79.904	Phosphorus	P	15	30.97376
Cadmium	Cd	48	112.41	Platinum	Pt	78	195.08
Cesium	Cs	55	132.9054	Plutonium	Pu	94	(244)
Calcium	Ca	20	40.08	Polonium	Po	84	(209)
Californium	Cf	98	(251)	Potassium	K	19	39.0983
Carbon	C	6	12.011	Praseodymium	Pr	59	140.9077
Cerium	Ce	58	140.12	Promethium	Pm	61	(145)
Chlorine	Cl	17	35.453	Protactinium	Pa	91	231.0359
Chromium	Cr	24	51.996	Radium	Ra	88	226.0254
Cobalt	Co	27	58.9332	Radon	Rn	86	(222)
Copper	Cu	29	63.546	Rhenium	Re	75	186.207
Curium	Cm	96	(247)	Rhodium	Rh	45	102.9055
Dysprosium	Dy	66	162.50	Rubidium	Rb	37	85.4678
Einsteinium	Es	99	(252)	Ruthenium	Ru	44	101.07
Erbium	Er	68	167.26	Samarium	Sm	62	150.36
Europium	Eu	63	151.96	Scandium	Sc	21	44.9559
Fermium	Fm	100	(257)	Selenium	Se	34	78.96
Fluorine	F	9	18.998403	Silicon	Si	14	28.0855
Francium	Fr	87	(223)	Silver	Ag	47	107.8682
Gadolinium	Gd	64	157.25	Sodium	Na	11	22.98977
Gallium	Ga	31	69.72	Strontium	Sr	38	87.62
Germanium	Ge	32	72.59	Sulfur	S	16	32.06
Gold	Au	79	196.9665	Tantalum	Ta	73	180.9479
Hafnium	Hf	72	178.49	Technetium	Tc	43	(98)
Helium	He	2	4.00260	Tellurium	Te	52	127.60
Holmium	Ho	67	164.9304	Terbium	Tb	65	158.9254
Hydrogen	H	1	1.00794	Thallium	Tl	81	204.383
Indium	In	49	114.82	Thorium	Th	90	232.0381
Iodine	I	53	126.9045	Thulium	Tm	69	168.9342
Iridium	Ir	77	192.22	Tin	Sn	50	118.69
Iron	Fe	26	55.847	Titanium	Ti	22	47.88
Krypton	Kr	36	83.80	Tungsten	W	74	183.85
Lanthanum	La	57	138.9055	Uranium	U	92	238.0289
Lawrencium	Lr	103	(260)	Vanadium	V	23	50.9415
Lead	Pb	82	207.2	Xenon	Xe	54	131.29
Lithium	Li	3	6.941	Ytterbium	Yb	70	173.04
Lutetium	Lu	71	174.967	Yttrium	Y	39	88.9059
Magnesium	Mg	12	24.305	Zinc	Zn	30	65.38
Manganese	Mn	25	54.9380	Zirconium	Zr	40	91.22
Medeleevium	Md	101	(258)				

¹ The atomic weight of many elements are not invariant but depend on the origin and treatment of the material. The values of atomic weight given here apply to elements as they exist naturally on Earth and to certain artificial elements. Values in parentheses are used for radioactive elements whose atomic weights cannot be quoted precisely without knowledge of the origin of the elements. The value given is the atomic mass number of the isotope of that element of longest known half-life.

This Page Intentionally Left Blank

APPENDIX E

HANDLING OF LIQUID HELIUM AND NITROGEN

E1.0 GENERAL

Liquid Helium (LHe) and liquid nitrogen (LN₂) are used in the operation of the MTD Series System. Although not explosive, there are a number of safety considerations to keep in mind in the handling of LHe and LN₂.

E2.0 PROPERTIES

LHe and LN₂ are colorless, odorless, and tasteless gases. Gaseous nitrogen makes up about 78 percent of the Earth's atmosphere, while helium comprises only about 5 ppm (Reference 1). Most helium is recovered from natural gas deposits. Once collected and isolated, the gases will liquefy when properly cooled. A quick comparison between LHe and LN₂ is provided in Table E-1.

Table E-1. Comparison of Liquid Helium to Liquid Nitrogen

PROPERTY	LIQUID HELIUM	LIQUID NITROGEN
Boiling Point @1 atm, in °K	4.2	77
Thermal Conductivity (Gas), w/cm-°K	0.083	0.013
Latent Heat of Vaporization, Btu/liter	2.4	152
Liquid Density, pounds/liter	0.275	0.78

E3.0 HANDLING CRYOGENIC STORAGE DEWARs

Cryogenic containers (dewars) must be operated in accordance with the manufacturer's instructions. Safety instructions will also be posted on the side of each dewar. Cryogenic dewars must be kept in a well-ventilated place where they are protected from the weather and away from any sources of heat. A typical cryogenic dewar is shown in Figure E-1.

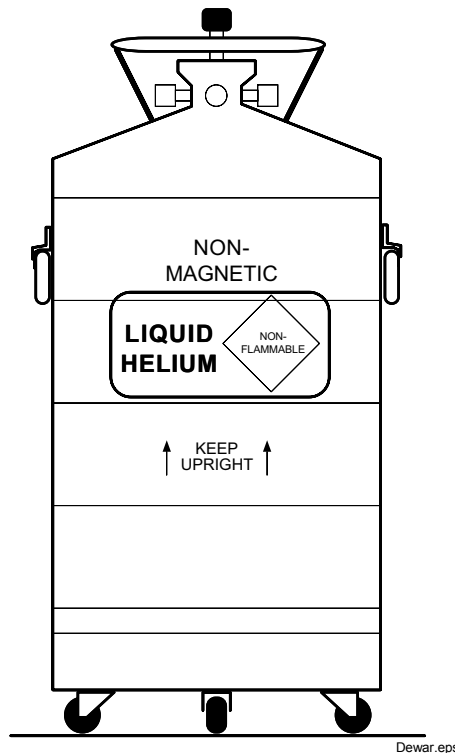

Figure E-1. Typical Cryogenic Storage Dewar

E4.0 LIQUID HELIUM AND NITROGEN SAFETY PRECAUTIONS

Transferring LHe and LN₂ and operation of the storage dewar controls should be in accordance with the manufacturer/supplier's instructions. During this transfer, it is important that all safety precautions written on the storage dewar and recommended by the manufacturer be followed.

WARNING: Liquid helium and liquid nitrogen are potential asphyxiants and can cause rapid suffocation without warning. Store and use in area with adequate ventilation. DO NOT vent container in confined spaces. DO NOT enter confined spaces where gas may be present unless area has been well ventilated. If inhaled, remove to fresh air. If not breathing, give artificial respiration. If breathing is difficult, give oxygen. Get medical help.

WARNING: Liquid helium and liquid nitrogen can cause severe frostbite to the eyes or skin. DO NOT touch frosted pipes or valves. In case of frostbite, consult a physician at once. If a physician is not readily available, warm the affected areas with water that is near body temperature.

The two most important safety aspects to consider when handling LHe and LN₂ are adequate ventilation and eye and skin protection. Although helium and nitrogen gases are non-toxic, they are dangerous in that they replace the air in a normal breathing atmosphere. Liquid products are of an even greater threat since a small amount of liquid evaporates to create a large amount of gas. Therefore, it is imperative that cryogenic dewars be stored and the MTD System be operated in open and well ventilated areas.

Persons transferring LHe and LN₂ should make every effort to protect eyes and skin from accidental contact with liquid or the cold gas issuing from it. Protect your eyes with full face shield or chemical splash goggles. Safety glasses (even with side shields) are not adequate. Always wear special cryogenic gloves (Tempshield Cryo-Gloves® or equivalent) when handling anything that is, or may have been, in contact with the liquid or cold gas, or with cold pipes or equipment. Long sleeve shirts and cuffless trousers that are of sufficient length to prevent liquid from entering the shoes are recommended.

E5.0 RECOMMENDED FIRST AID

Every site that stores and uses LHe and LN₂ should have an appropriate Material Safety Data Sheet (MSDS) present. The MSDS may be obtained from the manufacturer/distributor. The MSDS will specify the symptoms of overexposure and the first aid to be used. A typical summary of these instructions is provided as follows.

If symptoms of asphyxia such as headache, drowsiness, dizziness, excitation, excess salivation, vomiting, or unconsciousness are observed, remove the victim to fresh air. If breathing is difficult, give oxygen. If breathing has stopped, give artificial respiration. Call a physician immediately.

If exposure to cryogenic liquids or cold gases occurs, restore tissue to normal body temperature (98.6°F) as rapidly as possible, then protect the injured tissue from further damage and infection. Call a physician immediately. Rapid warming of the affected parts is best achieved by bathing it in warm water. The water temperature should not exceed 105 °F (40 °C), and under no circumstances should the frozen part be rubbed, either before or after rewarming. If the eyes are involved, flush them thoroughly with warm water for at least 15 minutes. In case of massive exposure, remove clothing while showering with warm water. The patient should not drink alcohol or smoke. Keep warm and rest. Call a physician immediately.

References:

1. Linde Union Carbide Document No. L-3499H, Dated December 1988, Safety Precautions for Oxygen, Nitrogen, Argon, Helium, Carbon Dioxide, Hydrogen, and Fuel Gases