

Instructions, GaAlAs Diode Temperature Sensor Installation, Model TG-120-CO Package



There are three aspects of using a temperature sensor which are critical to its optimum performance. The first involves the proper mounting of the sensor package, the second relates the proper joining of sensor lead wires and connecting wires. The final concern is the thermal anchoring of the lead wires. Although the sequence in which these areas should be addressed is not set in stone, all elements covered under each aspect should be adhered to for maximum operating capabilities of the sensor.

SENSOR MOUNTING

The TG-120-CO package combines a standard SD sensor with a spring loaded copper clamp assembly to form the CO package. The clamp has a formed shoulder so that, once the screw is properly seated, the spring applies correct pressure to the clamp.

1. A 4-40 threaded hole in the mounting surface for CO adapter must be at least 5 mm (0.2 in) deep.
2. Surface area should be prepared and cleaned with a solvent such as acetone followed by an isopropyl alcohol rinse. Allow time for the solvents to evaporate before sensor mounting.
3. A small amount of Apiezon® N grease should be applied between the mounting surface and the sensor to enhance thermal contact.

NOTE: An overabundance of grease will increase the thermal barrier. Keep the thickness to 0.05 mm or less.

NOTE: It is important that if using an electrically conductive grease that the excess does not “creep-up” the edges of the sensor or come in contact with the sensor leads. There is a thin braze joint around the sides of the SD sensor and is electrically connected to the sensing element. Contact to the sides with any electrically conductive material will cause a short.

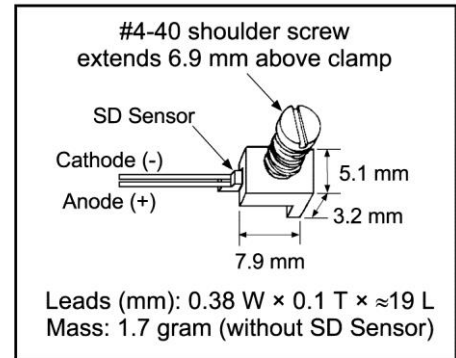

4. Remove plastic cap which holds the three piece CO assembly together. Keep the spring and clamp intact with the screw.
5. Apply a small amount of Apiezon® N grease to the threads and screw the assembly into the threaded hole on mounting surface. Tighten screw enough so that it will stand alone.
6. Lift the edge of the clamp with small pliers or screwdriver. Slide sensor into place between mounting surface and the notched section of the clamp. Gently lower the clamp on the sensor. Make sure the sensor base is resting on the mounting surface. The base is the largest flat area of the sensor.
7. Tighten screw until it no longer turns. The shoulder on the screw should rest against the mounting surface and also prevents over compressing of the spring. Package design will prevent damage to the sensor due to over tightening.

NOTE: During any point of sensor installation and use, do not heat sensor above 200 °C.

LEAD ATTACHMENT

It is recommended that a 4-lead measurement scheme is used with this sensor. Attaching four connecting wires to the sensor leads is recommended. To determine lead polarity, when viewed with the base down and the leads towards the observer, the positive lead (anode) is on the right and the negative (cathode) is on the left.

1. Prepare the sensor leads and connecting lead wires with a RMA (rosin mildly active) soldering flux, tin them with a minimal amount of 60% Sn 40% Pb solder. Use a low wattage soldering iron that will not exceed 200 °C. Clean off residual flux with rosin residue remover. The sensing element inside the package should be protected from excessive heat by putting a heat sink clip over the package.
2. Strip connecting wires insulation by delicately scraping with a razor blade, fine sand paper or steel wool. Phosphor-bronze or Manganin wire, in sizes 32 or 36 AWG, is commonly used as the connecting lead wire. These wires have low thermal conductivity which help minimize the heat flow through the leads. Typical wire insulation is Formvar™ or polyimide (Formvar™ insulation has better mechanical properties such as abrasion resistance and flexibility. Polyimide insulation has better resistance to chemical solvents and burnout).
3. Prepare the connecting wire ends with a RMA (rosin mildly active) soldering flux, tin them with a minimal amount of 60% Sn/40% Pb solder. Use a low wattage soldering iron which will not exceed 200 °C.
4. Clean off residual flux with rosin residue remover. The sensor lead can be prepared in an identical manner.

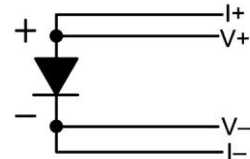

Recommended Wire Hook Up

5. Attach one sensor lead with two of the connector wires and apply the soldering iron above the joint area until the solders melt, then remove the iron immediately. Repeat for the other set of connector wires and the other sensor lead.
6. Avoid putting stress on the device leads and leave enough slack to allow for the thermal contractions that occur during cooling which could fracture a solder joint or lead.

HEAT SINKING/THERMAL ANCHORING

1. Since the area being measured is read through the base of the sensor, heat flow through the connecting leads can create an offset between the sensor chip and the true sample temperature. Thermal anchoring of the connecting wires is necessary to assure that the sensor and the leads are at the same temperature as the sample.
2. Connecting wires should be thermally anchored at several temperatures between room temperature and cryogenic temperatures to guarantee that heat is not being conducted through the leads to the sensing element.
3. If the connecting leads have a thin insulation such as Polyvinyl Formal (Formvar™) or Polyimide (ML), a simple thermal anchor can be made by winding the wires around a copper post, bobbin or other thermal mass. A minimum of five wraps around the thermal mass should provide enough of an anchor. However, if space permits, additional wraps are recommended for good measure. To maintain good electrical isolation over many thermal cycles, it is good practice to first varnish a single layer of cigarette paper to the anchored area then wrap the wire around the paper and bond in place with a thin layer of IMI 7031 Varnish. Formvar™ wiring insulation has a tendency to craze with the application of IMI varnish. Once IMI varnish is applied, the wires cannot be disturbed until all solvents have evaporated and the varnish has fully cured (typically 12 to 24 h).
4. A final thermal anchor at the sample itself is a good practice to ensure thermal equilibrium between the sample and temperature sensor.

CRYOGENIC ACCESSORIES – Recommended for proper installation and use of TG-120-CO sensors:

Stycast® Epoxy 2850FT (P/N 9003-020, 9003-021): Permanent attachment, excellent low temperature properties, poor electrical conductor, and low cure shrinkage.

Apiezon® N Grease (P/N 9004-020): Low viscosity, easy to use, solidifies at cryogenic temperatures, excellent lubricant.

IMI 7031 Varnish (P/N 9009-002): Nonpermanent attachment, excellent thermal conductor, easy to apply and remove.

Indium Solder (P/N 9007-002-05): 99.99% pure, excellent electroplating material, foil form.

90% Pb 10% Sn Solder (P/N 9008-001): Greater lead content, for higher temperature applications no greater than 200 °C.

RMA Soldering Flux (P/N 9008): Variety of types, refer to Lake Shore Product Catalog for details.

Phosphor-Bronze Wire (P/N 9001-00X): Available in single, duo, and quad strands, no magnetic attraction, low thermal conduction.

Manganin Wire (P/N 9001-00X): Low thermal conductivity, high resistivity, no magnetic attraction.

Heat Sink Bobbin (P/N 9007-900 Large, 9007-901 Small): Gold plated oxygen-free high-conductivity (OFHC) copper bobbins.

Instruments: Lake Shore sells a complete line of instrumentation used with the TG-120-CO sensors, such as current sources, cryopump monitors, temperature controllers, monitors and thermometers, temperature scanners and transmitters.

For complete product description and detailed specifications on the above accessories and instruments, consult the Lake Shore Temperature Measurement and Control Catalog, call at (614) 891-2243, E-mail at sales@lakeshore.com, or visit our website at www.lakeshore.com.