



Model FWPX 4-INCH WAFER CRYOGENIC PROBE STATION

Introduction

The Model FWPX is a versatile cryogenic micro-manipulated probe station used for non-destructive testing of devices on full and partial wafers up to 102 mm (4 in) in diameter. The FWPX is a platform for measurement of electrical, electro-optical, parametric, high Z, DC, RF, and microwave properties of materials and test devices. Nanoscale electronics, quantum wires and dots, and semiconductors are typical materials measured in a FWPX. A wide selection of probes, cables, sample holders, and options makes it possible to configure the FWPX to meet your specific measurement applications.

The FWPX operates over a temperature range of 4.5 K to 475 K. With options, the base temperature can be extended down to 3.5 K. The probe station provides efficient temperature operation and control with a continuous refrigeration system using either helium or nitrogen. Vapor-cooled shielding optimizes efficiency and intercepts blackbody radiation before it reaches the sample. Two control heaters on the sample stage minimize temperature gradients across the sample and, along with the radiation shield heater, provide the probe station with fast thermal response.

The FWPX is user-configured with up to six ultra-stable micro-manipulated stages, each providing precise 3-axis control of the probe position to accurately land the probe tip on device features. The sample stage provides in-plane translation and rotation to allow alignment of patterns with stage axes. Proprietary probe tips in a variety of sizes and materials minimize thermal mass and optimize electrical contacts to the device under test (DUT). Probe tips are thermally linked to the sample stage to minimize heat transfer to the DUT.

For increased versatility, FWPX options include a 3.5 K base temperature stage, LN₂ Dewar kit, pump line vibration isolator, higher magnification microscope, vacuum turbo pumping system, and fiber optic probe arm modification.

Features

- High stability operation from 3.5 K to 475 K
- Measurements from DC to 67 GHz
- Accommodates up to 102 mm (4 in) diameter wafers
- Configurable with up to six thermally anchored micro-manipulated probe arms
- Probe arms with 3-axis adjustments and $\pm 5^\circ$ planarization
- Sample stage with in-plane translation and $\pm 5^\circ$ in-plane rotation
- Cables, shields, and guards minimize electrical noise and thermal radiation losses
- Options and accessories for customization to specific research needs

Lake Shore Cryotronics, Inc.

575 McCorkle Boulevard ■ Westerville, Ohio 43082

Phone 614-891-2244 ■ Fax 614-818-1600

info@lakeshore.com ■ www.lakeshore.com

All specifications subject to change. Rev 7/7/2010

Applications

- Electrical and electro-optical measurements over a wide temperature range
- RF and microwave
- Parametric testing
- Shielded/guarded/low noise characterization
- High Z
- Non-destructive, full wafer testing

Materials

- Nanoscale electronics (carbon nanotube transistors, single electron transistors, molecular electronics, nanowires, etc.)
- Quantum wires and dots, quantum tunneling
- Single electron tunneling (Coulomb blockade)
- Basic semiconductor devices including organics, LEDs, and dilute magnetic semiconductor

Specifications

Temperature

Sample temperature range—standard	4.5 K to 475 K
Sample temperature range—optional	3.5 K to 475 K*
Temperature control (heaters)	
Sample stage	100 W (2 parallel heaters, 50 W each)
Radiation shield	100 W
Probe arm	Measurement only

*Selectable equipment

Probe Arm and Sample Stage Adjustments

Probe arm travel	
X axis	127 mm (5 in)
Y axis	51 mm (2 in)
Z axis	18 mm (0.7 in)
Translation scale	
X axis	20 μm
Y and Z axes	10 μm
Planarization*	±5°
Sample stage (sample holder)	
In-plane rotation	±5°
In-plane translation	Yes

*Included with microwave probes

Frequency Range

ZN50 DC/RF probe frequency range	
Tungsten with cryogenic coaxial cable	0 to 50 MHz*
Tungsten with semirigid coaxial cable	0 to 1 GHz*†
Paliney 7 with cryogenic coaxial cable	0 to 50 MHz*
Paliney 7 with semirigid coaxial cable	0 to 1 GHz*†
BeCu with cryogenic coaxial cable	0 to 50 MHz*
BeCu with semirigid coaxial cable	0 to 1 GHz*†
GSG microwave probe frequency range	
Low frequency with K connector	0 to 40 GHz*
Mid frequency with 2.4 mm connector	0 to 50 GHz*
High frequency with 1.85 mm connector	0 to 67 GHz*

*Selectable equipment

† S21 > -10 dB up to 1 GHz, except for a (-40 dB) spike between 400 MHz and 800 MHz depending on probe model and placement; S11 < -3 dB up to 1 GHz

Optical

Optical viewport—located on top lids	Ø91 mm (3.6 in) outer window and Ø152 mm (6 in) inner window
Outer, clear fused quartz	99% IR transmittance
Inner	IR absorbing with narrow band visible light transmittance
Optical resolution—microscope	
7:1 zoom	8 µm
16:1 zoom	8 µm*

*Selectable equipment

Sample Holder (Chuck)

Maximum sample size—overall	Up to Ø102 mm (4 in)
SH-4.00-4G, grounded chuck	Up to Ø102 mm (4 in) and 475 K
SH-4.00-4C, coaxial chuck	Up to Ø102 mm (4 in) and 400 K*
SH-4.00-4T, triaxial chuck	Up to Ø102 mm (4 in) and 400 K*

*Selectable equipment

Standard Equipment

Flow cryostat	4.5 K to 475 K
Sample stage temperature sensor	Lake Shore Model DT-670-SD-1.4H calibrated silicon diode
Sample stage heater	100 W (2 parallel heaters, 50 W each)
Cooled radiation shield and cooled IR-absorbing window above the sample	
Temperature sensor	Lake Shore Model DT-670C-CU silicon diode
Radiation shield heater	100 W
Removable top lid with viewport	Ø152 mm (6 in) window
Temperature control	One Lake Shore Model 336 temperature controller and one Model 142 200 W (two channels, 100 W each) power supply (independent regulation of sample stage and radiation shield, and probe arm temperature monitoring)
Electroless nickel-plated aluminum vacuum chamber	
Diameter	254 mm (10 in)
Removable top lid with clear fused quartz viewport	Ø91 mm (3.6 in) window
Probe ports	6 surround the sample thermal radiation shield
Pump port	NW 40 (pump sold separately)
Gas purge and 0.5 psi safety pop-off port	NW 25
Spare port	NW 25
Machined aluminum base plate	846 mm ² (33.3 in ²)
PS-TMC vibration isolation system	
	Includes pneumatically driven gimbal piston isolator, actuators, and supports; self leveling with a resonant frequency below 2 Hz; requires 40 psi nitrogen or air
Isolator natural frequency	Vertical 0.8 Hz, horizontal 1.0 Hz
Isolation efficiency at 5 Hz	Vertical 80 to 97%, horizontal 60 to 90%
Isolation efficiency at 10 Hz	Vertical 90 to 99%, horizontal 70 to 95%
Temperature sensor installed and wired to a 6-pin feedthrough (included on one probe arm)	
Grounded sample holder	SH-4.00-4G, accommodates up to a Ø102 mm (4 in) sample with a Ø102 mm (4 in) probe area
Optics	
Zoom 70 microscope	7:1 zoom with 8 µm resolution
Color CCD camera	S-video or composite output format
Swing arm	Optics can be manipulated to view any part of the sample or wafer, and can be retracted and swung away to allow access to the top of the vacuum chamber for sample exchange
Video monitor	High resolution, 17-inch
Sample illumination	Coaxial via fiber optic or ring light from an adjustable light source and power supply (must specify sample illumination at time of order) NOTE: Coaxial illumination is recommended for highly reflective materials
High efficiency helium transfer line with foot valve for precise flow regulation	
Instrument console	
Basic tools and spares kit for standard operation	

Required User Configurable Equipment — Micro-manipulated Stages, Probes, Probe Tips, and Cables

MICRO-MANIPULATED STAGES

Part Number	Description
MMS-13	Micro-manipulated stage with thermal radiation shields, stainless steel welded bellows, and feedthrough ports—includes probe arm and base; probes, probe tips, and cables sold separately

ZN50 DC/RF PROBES

- Ideal for: DC biasing, low/high frequency measurements, low noise shielded, and low-leakage guarded measurement
- ZN50 probe base incorporates a pair of copper braids that anchor to the sample stage to dynamically cool/heat the probe to the sample temperature
- SMA connector mounted directly to a replaceable alumina ceramic blade with a 50 Ω stripline routed to the probe contact

We understand that today's researcher requires flexibility. Our wide selection of probes, cables, sample holders, and options make it possible to configure a probe station to meet your specific measurement applications.

Part number (probe body)	Description
ZN50-55I	50 Ω stripline probe body mount (Each probe body mount requires a ceramic blade—selectable below)

Part number (ceramic blade)	Tip material	Maximum frequency (GHz)	Maximum probe temperature*	Maximum sample temperature**	Tip radius (μm)
ZN50R-03-W	Tungsten	1 Maximum frequency 50 MHz with ZN50C-G or ZN50C-T cable; maximum frequency 1 GHz with MWC-13-00K cable	350 K	475 K	3
ZN50R-10-W					10
ZN50R-25-W					25
ZN50R-03-P7	Paliney 7				3
ZN50R-10-P7					10
ZN50R-25-P7					25
ZN50R-03-BECU	BeCu				3
ZN50R-10-BECU					10
ZN50R-25-BECU					25
ZN50R-100-BECU					100
ZN50R-200-BECU					200

* As measured by the probe arm temperature sensor

** Selectable equipment

ZN50 DC/RF CABLES

Part number	Cable type	Connector type	Feedthrough type	Measurement configuration	Maximum frequency	Maximum cable temperature*	Maximum sample temperature**
ZN50C-G	Ultra-miniature cryogenic coaxial	SMA	BNC	Shielded	50 MHz	350 K	475 K
ZN50C-T	Ultra-miniature cryogenic coaxial	SMA	3-lug triaxial	Low leakage	50 MHz		
MWC-13-00K	Semirigid microwave coaxial	K (SMA compatible)	Loss-less compression seal	High frequency	1 GHz [†]		

* As measured by the probe arm temperature sensor

** Selectable equipment

[†] S21 > -10 dB up to 1 GHz, except for a (-40 dB) spike between 400 MHz and 800 MHz depending on probe model and placement; S11 < -3 dB up to 1 GHz

GSG MICROWAVE PROBES

- Coplanar waveguide probe with ground-signal-ground (GSG) contact geometry
- User-specified pitch (spacing)
- Optimized low thermal conductivity coaxial leading to low thermal conductivity tips
- Include a copper braid assembly to cool the probe to near sample temperature
- Limited to 350 K
- Separate planarization module with $\pm 5^\circ$ rotation mechanism is provided

Part number	Connector type	Maximum frequency (GHz)	Maximum probe temperature*	Maximum sample temperature**	Pitch (μm)
GSG-050-40A-55I-E	K	40	350 K	475 K	50
GSG-100-40A-55I-E					100
GSG-150-40A-55I-E					150
GSG-200-40A-55I-E					200
GSG-250-40A-55I-E					250
GSG-050-50A-55I-E	2.4 mm	50			50
GSG-100-50A-55I-E					100
GSG-150-50A-55I-E					150
GSG-200-50A-55I-E					200
GSG-250-50A-55I-E					250
GSG-050-67A-55I-E	1.85 mm	67			50
GSG-100-67A-55I-E					100
GSG-150-67A-55I-E					150
GSG-200-67A-55I-E					200
GSG-250-67A-55I-E					250

* As measured by the probe arm temperature sensor

** Selectable equipment

GSG MICROWAVE CABLES

- Loss-less compression seal
- Semirigid with Teflon® dielectric

Part number	Cable type	Feedthrough type	Maximum cable temperature*	Maximum sample temperature**	Connector type	Maximum frequency
MWC-13-00K	Semirigid microwave coaxial	Loss-less compression seal	350 K	475 K	K (SMA compatible)	40 GHz
MWC-13-240					2.4 mm	50 GHz
MWC-13-185					1.85 mm	67 GHz

* As measured by the probe arm temperature sensor

** Selectable equipment

Sample Holders (Chucks)

Typical sample holder configuration characterized by:

- Leakage resistance between
 - Top surface and guard
 - Guard and ground
- Capacitance between
 - Top surface and guard
 - Guard and ground

Types of sample holders

- Grounded sample holder—sample mount surface at system ground
- Isolated sample holder—backside contact not needed; sample mount surface is electrically non-conductive and isolated from ground
- Coaxial sample holder—backside contact can be made; sample mount surface is isolated from ground
- Triaxial sample holder—guarded backside contact can be made; sample mount surface has guarded isolation from ground

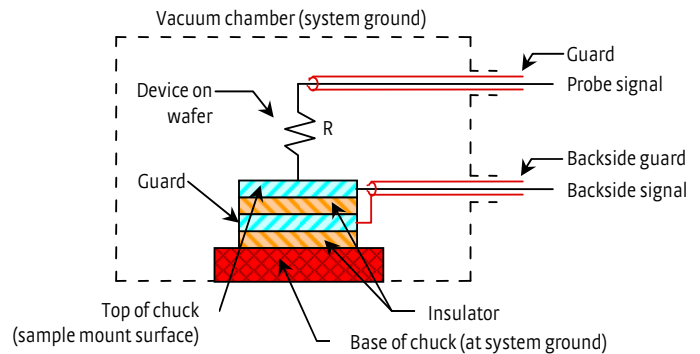

Part number	Measurement configuration	Separate feedthrough required	Maximum sample (diameter)	Maximum temperature
SH-4.00-4G	Grounded	No	Ø102 mm (4 in)	475 K
SH-4.00-4C	Coaxial	Yes*		400 K
SH-4.00-4T	Triaxial	Yes**		

*Coaxial sample holders require one FT-BNC or FT-TRIAX feedthrough as listed below

**Triaxial sample holders require one FT-TRIAX feedthrough as listed below

Part number	Description
FT-BNC	Coaxial feedthrough and coaxial cable, installed and wired
FT-TRIAX	Triaxial feedthrough and coaxial cable, installed and wired

Equipment Options

Part number	Description
PS-FOA	Fiber optic probe arm modification. Transmit or receive light or IR/UV radiation. Fiber optic terminated with SMA connector or compression feedthrough. (Fiber optic wire not included. Fiber optic and probe cannot be used simultaneously.)
PS-Z16	16:1 zoom microscope upgrade; provides 8 µm resolution NOTE: consult Lake Shore for field upgrade
PS-LT	3.5K base temperature stage pumping option—includes system modifications, stainless steel flex hose for pump connection, and Varian DS402 rotary pump (12.3 CFM at 60 Hz with oil mist eliminator on output [with oil return], inlet oil demister); 50 Hz operation may increase base temperature
PS-PLVI-25	Pump-line vibration isolator—includes NW 25 fittings, 1 m stainless steel bellows, clamps, and rings (placed between pump cart and system); requires one bag of cement. NOTE: for use with PT-LT
PS-DPC	Automatic Dewar (gas) pressure controller, regulates Dewar liquid flow
PS-V81DPC	Compact turbo pumping system—includes Varian V-81 turbo pump with oil free dry scroll backing pump, vacuum gauge for high vacuum, controller, and adaptors (specify 120 V/60 Hz or 220 V/50 Hz)
PS-PLVI-40	Pump-line vibration isolator—includes NW 40 fittings, 1 m stainless steel bellows, clamps, and rings (placed between pump cart and system); requires one bag of cement. NOTE: for use with PS-V81DP
PS-LN2	Nitrogen Dewar with stainless fittings, gauges, and adaptors; allows LN ₂ use with the LHe transfer line
PS-OAC	Oil-less compressor for PS-TMC (only available in 120 V)
PA-SEN	Probe arm modification with temperature sensor installed and wired to a 6-pin feedthrough
PS-PAB-13	Probe arm and base
CS-5	Calibration substrate for GSG probes—pad size: 50 µm ² ; calibration type: SOLT (short-open-load-through), LRL (line-reflective-line), LRM (line-reflective-match); pitch range: 75 to 250 µm
CS-15	Calibration substrate for GSG probes—pad size: 25 µm ² ; calibration type: SOLT (short-open-load-through), LRL (line-reflective-line), LRM (line-reflective-match); pitch range: 40 to 150 µm

Lake Shore Cryotronics is a leading supplier of cryogenic, superconducting magnet-based, electromagnet-based, high vacuum, and load-lock probe stations. We offer a full line of standard probe stations to meet your research requirements.

Our standard line of probe stations includes:

Model TTPX

- Up to six micro-manipulated probe stages
- Temperature range capabilities from 3.2 K to 675 K
- Up to 51 mm (2 in) diameter wafer capabilities
- Optical access through sample stage

Model CPX

- Up to six micro-manipulated probe stages
- Temperature range capabilities from 1.5 K to 675 K
- Up to 51 mm (2 in) diameter wafer capabilities
- $\pm 5^\circ$ sample stage rotation
- Load-lock and high vacuum options

Model FWPX

- Up to six micro-manipulated probe stages
- Temperature range capabilities from 3.5 K to 475 K
- $\pm 5^\circ$ sample stage rotation
- Up to 102 mm (4 in) diameter wafer capabilities

Model CPX-HF

- 1 T horizontal field split pair superconducting magnet
- Up to four micro-manipulated probe stages
- Temperature range capabilities from 2 K to 400 K with field on or off
- $\pm 5^\circ$ sample stage rotation
- Up to 25 mm (1 in) diameter wafer capabilities
- High vacuum option

Model CPX-VF

- 2.5 T vertical field solenoid superconducting magnet
- Up to six micro-manipulated probe stages
- Temperature range capabilities from 2 K to 400 K with field on or off
- $\pm 5^\circ$ sample stage rotation
- Up to 51 mm (2 in) diameter wafer capabilities
- High vacuum option

Model EMPX-HF

- 0.55 T horizontal (in-plane field) electromagnet
- Up to four micro-manipulated probe stages
- Temperature range capabilities from 3.2 K to 400 K
- Up to 25 mm (1 in) diameter wafer capabilities
- 360° sample stage rotation option

Model CRX-4K

- Low vibration, cryogen-free closed cycle refrigerator
- Up to six micro-manipulated probe stages
- Temperature range capabilities from 4.5 K to 475 K
- Up to 51 mm (2 in) diameter wafer capabilities