

# Installation Instructions

## Silicon Diode Temperature Sensor

### DT-470/471/670 BO and BR Packages



There are three aspects of using a cryogenic temperature sensor which are critical to its optimum performance. The first involves the proper mounting of the sensor package, the second relates the proper joining of sensor lead wires and connecting wires. The final concern is the thermal anchoring of the lead wires. Although the sequence in which these areas should be addressed is not set in stone, all elements covered under each aspect should be adhered to for maximum operating capabilities of the sensor.

#### SENSOR MOUNTING

The DT 470/471/670 BO/BR packages combines a standard SD sensor soldered to a gold-plated copper mounting block. The mounting block of these packages contain a 2.95 mm (0.116 inch) diameter hole designed for mounting with a #4-40 screw.

1. A threaded hole in your mounting surface is necessary for mounting the sensor package. The through hole in the sensor package will accommodate a #4-40 brass machine screw. Brass is recommended due to the thermal contractions/expansions of the final assembly.
2. Threaded hole and surrounding surface should be cleaned using a solvent such as Acetone followed by an Isopropyl Alcohol rinse. Allow time for the solvents to evaporate before mounting.
3. Apply a small amount of Apiezon<sup>®</sup> N grease to the threads of the screw. To ensure good thermal contact between the sensor and mounting surface use an indium washer/preform or thin layer of Apiezon<sup>®</sup> N grease between the mounting surface and the sensor package.

**NOTE:** An overabundance of grease will increase the thermal barrier. Keep the thickness to 0.05 mm or less.

4. Insert screw through sensor mounting block and tighten screw into place.

**NOTE:** Ensure that no electrically conductive particles lodge between the mounting block and the SD sensor. There is a thin braze joint around the sides of the SD sensor that is electrically connected to the sensing element. Contact to the sides with any electrically conductive material will cause a short. This package is designed for use up to 325 K (52 °C), subjecting to temperature in excess of this may cause a shift in the sensor values.

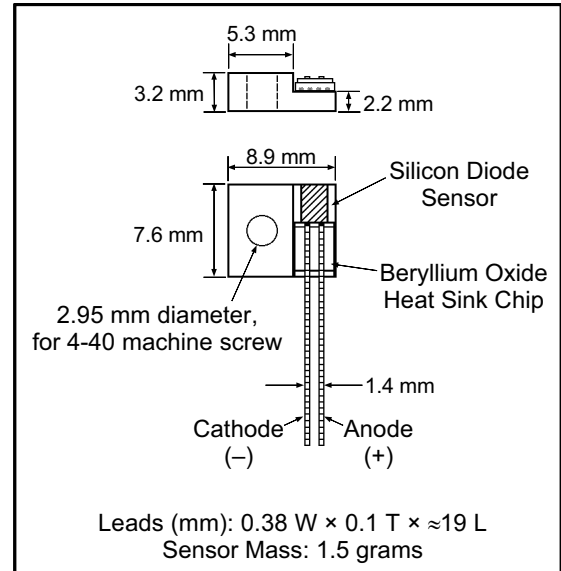

#### LEAD ATTACHMENT

In addition to being soldered to the mounting block, the SD sensor has its leads thermally anchored to the block with a beryllium oxide heat sink chip. The heat sink chip is used as a buffer layer to take up expansion mismatch between an object with large expansion coefficient (copper block) and an object with a low expansion coefficient (SD sensor). The BO package has two gold plated Kovar leads and are a minimum of 12.7 mm (0.5 inch) in length. The BR package has four 36 AWG Polyvinyl Formal (Formvar<sup>™</sup>) insulated, phosphor bronze leads, 0.91 m (36 inch) in length attached to the sensor.

#### BO Package

It is recommended that a 4-lead measurement scheme is used with this sensor. Attaching four connecting wires to the sensor leads is recommended. To determine lead polarity, when viewed with the base down and the leads towards the observer, the positive lead (anode) is on the right and the negative (cathode) is on the left.

1. Prepare the sensor leads and connecting lead wires with a RMA (rosin mildly active) soldering flux, tin them with a minimal amount of 60% Sn 40% Pb solder. Use a low wattage soldering iron that will not exceed 200 °C. Clean off residual flux with rosin residue remover. The sensing element inside the package should be protected from excessive heat by putting a heat sink clip over the package.
2. Strip the insulation from the connecting wires by delicately scraping with a razor blade, fine sand paper, or steel wool. Phosphor-bronze or manganin wire, in sizes 32 or 36 AWG, is commonly used as the connecting lead wire. These wires have low thermal conductivity and high resistivity which help minimize the heat flow through the leads. Typical wire insulation is Formvar<sup>™</sup> or Polyimide (ML). Formvar<sup>™</sup> insulation has better mechanical properties such as abrasion resistance and flexibility. Polyimide insulation has better resistance to chemical solvents and burnout.

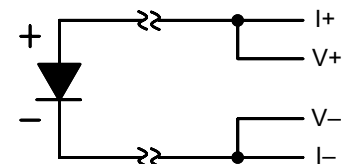

Two-Lead Measurement Scheme

- Attach one sensor lead with two of the connector wires and apply the soldering iron above the joint area until the solders melt, then remove the iron immediately. Repeat for the other set of connector wires and the other sensor lead. Leave enough slack to allow for the thermal contractions that occur during cooling which could fracture a solder joint or lead. Insulating the soldering joint is recommended. This can be achieved with heat shrink tubing.

**NOTE:** Be sure when soldering, or any time during use, the package does not exceed 325 K (52 °C). Exceeding this temperature may cause a shift in the sensor values.

### BR Package

The BR package has a built in 4-lead measurement scheme. The current is confined to one pair of current leads with the sensor voltage measured using the remaining lead pair which is not carrying current. Sensor lead polarity: Red (I-), Clear (V-), Green (V+), Blue (I+).

Thirty-six inches of lead wire is attached during the production process. If additional connection wire is required, follow the connection steps for the BO package. (Refer to Step 1 above.)

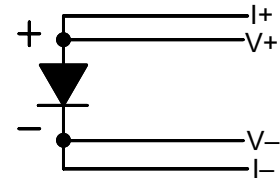

Recommended Wire Hook Up

### HEAT SINKING/THERMAL ANCHORING

Since the area being measured is read through the base of the sensor, heat flow through the connecting leads can create an offset between the sensor chip and the true sample temperature. Thermal anchoring of the connecting wires is necessary to assure that the sensor and the leads are at the same temperature as the sample.

- Connecting wires should be thermally anchored at several temperatures between room temperature and cryogenic temperatures to guarantee that heat is not being conducted through the leads to the sensing element. The leads of the BO and BR packages are thermally anchored to the mounting block with a beryllium oxide heat sink chip.
- If the sensing leads or connecting wires have a thin insulation such as Formvar™ (BR package) or Polyimide, a simple thermal anchor can be made by winding the wires around a copper post, bobbin, or other thermal mass. A minimum of five wraps around the thermal mass should provide sufficient thermal anchoring. However, if space permits, additional wraps are recommended for good measure. To maintain good electrical isolation over many thermal cycles, it is good practice to first varnish a single layer of cigarette paper to the anchored area then wrap the wire around the paper and bond in place with a thin layer of IMI 7031 Varnish. Formvar™ wiring insulation has a tendency to craze with the application of IMI varnish. Once IMI varnish is applied, the wires cannot be disturbed until all solvents have evaporated and the varnish has fully cured (typically 12 – 24 hours).
- As a minimum, one of the thermal anchors should be as close as possible to the sample itself to ensure thermal equilibrium between the sample and temperature sensor.

**CRYOGENIC ACCESSORIES** – Recommended for proper installation and use of DT-470/471/670 BO and BR Sensors:

**Stycast Epoxy® 2850FT** (P/N 9003-020, 9003-021): Permanent attachment, excellent low temperature properties, poor electrical conductor, low cure shrinkage.

**Apiezon® N Grease** (P/N 9004-020): Low viscosity, easy to use, solidifies at cryogenic temperatures, excellent lubricant.

**IMI 7031 Varnish** (P/N 9009-002): Nonpermanent attachment, excellent thermal conductor, easy to apply and remove.

**Indium Solder** (P/N 9007-002-05): 99.99% pure, excellent electroplating material, foil form.

**90% Pb 10% Sn Solder** (P/N 9008-001): Greater lead content, for higher temperature applications no greater than 200 °C.

**RMA Soldering Flux** (P/N 9008): Variety of types, refer to Lake Shore Product Catalog for details.

**Phosphor-bronze Wire** (P/N 9001-00X): Available in single, duo, and quad strands, no magnetic attraction, low thermal conduction.

**Manganin Wire** (P/N 9001-00X): Low thermal conductivity, high resistivity, no magnetic attraction.

**Heat Sink Bobbin** (P/N 9007-900 Large, 9007-901 Small): Gold plated oxygen-free high-conductivity (OFHC) copper bobbins.

**Instruments:** Lake Shore sells a complete line of instrumentation used with the DT-470/471/670 Sensors, such as: Current Sources, Cryopump Monitors, Temperature Controllers, Monitors and Thermometers, Temperature Scanners and Transmitters.

For complete product description and detailed specifications on the above accessories and instruments, consult the Lake Shore Temperature Measurement and Control Catalog, call at (614) 891-2243, e-mail at sales@lakeshore.com, or visit our website at www.lakeshore.com.